

**WORKSHOP MANUAL**  
**FOR 1<sup>st</sup> SEMESTER**  
**DIPLOMA**  
**FOR ALL BRANCH OF ENGINEERING**  
As per revised new Curriculum of S.C.T.E. &V.T ,Odisha

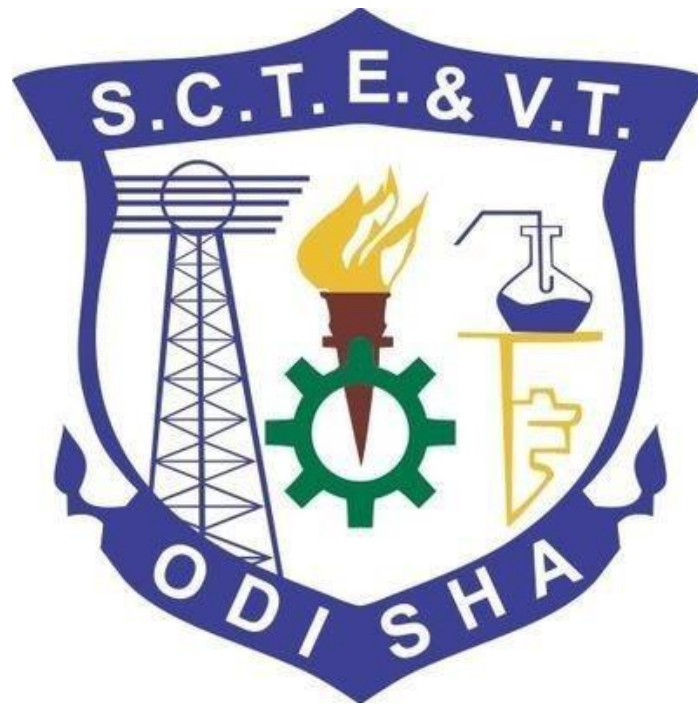

**STATE COUNCIL FOR TECHNICAL EDUCATION  
& VOCATIONAL TRAINING, ODISHA,  
BHUBANESWAR**

# SYLLABUS

Theory: 6 Periods per Week  
Total Periods: 90 Periods  
Examination: 4 Hours

Sessional : 50 Marks  
End Sem Exams : 100 Marks  
TOTAL MARKS : 150 Marks

## Objective:

1. To demonstrate safely practice in various shops of the workshop.
2. To select suitable tools & equipment in the following shops. (a) Fitting.(b) Sheet Metal.(c) Welding (Gas & Electrical). (d) Turning.
3. To select suitable materials for different process in the above shops.
4. To demonstrate the different processes adopted in the above shops.
5. To finish the jobs within stipulated time and with accuracy as per specifications.

## Topic Wise distribution of periods

Sl. No.		Periods
1	Fitting Shop	24
2		18
3		24
4	Turning Shop	21
5	Exposure to CNC Milling / Lathe Machine	03
	<b>TOTAL</b>	<b>90</b>

## 1. FITTING SHOP

- 1.1 Demonstrate safety practices in the fitting shop.
- 1.2 Select suitable holding & clamping devices for fitting jobs.
- 1.3 Select suitable tools like- files, vice, chisels, punch, scriber, hammers, surface plate, V-block, try square, caliper etc.
- 1.4 Demonstrate the following operations: Sawing, Chipping, Fitting, Scraping, Grinding, Marking, Reaming, Tapping, Drilling & Angular cutting.
- 1.5 Introduction of chipping, demonstration on chipping and its applications.
- 1.6 Description, demonstration and practice of simple operation of hack saw straight and angular cutting.
- 1.7 Introduction and use of measuring tools used in fitting shop like steel rule, measuring tape, outside micrometer, vernier caliper and vernier height gauge.
- 1.8 Description and Demonstration and practice of thread cutting using taps and dies.

**Job: Cutting & fitting practice on a square of 50mm X 50mm X 8mm MS Flat. Job: Angular cutting practice of 45 degree (on the above job).**

**Job: Preparation of stud (to cut external threads) with the help of dies (mm or BSW).**

**Job: H-fitting in the mild steel (MS) square.**

**Job: Prepare one job on male female fitting.**

## **2. SHEET METAL**

2.1 Demonstrate safety practices in sheet metal shop.

2.2 Prepare surface development for the jobs according to the drawing.

2.3 Cut M.S and G.P. sheets according to the surface development / drawing using standard sheet metal cutting tools.

2.4 Select hand tools for sheet metal work.

2.5 Demonstrate the process of metal clamp joining and reveted joining of sheet metals.

**Job: Making of sheet metal joints.**

**Job: Prepare a sheet metal tray or a funnel.**

**Job: Prepare a sheet metal job involving rolling, shearing, creasing, bending & cornering.**

**Job: Prepare a lap riveting joint.**

## **3. WELDING SHOP**

3.1 Introduction.

3.2 Safety precautions in welding, safety equipments & its application in welding shop.

3.3 Introduction to welding, type of welding, common materials that can be welded, introduction to gas welding equipment, types of flame, adjustment of flame, applications of gas welding, Welding tools & safety precautions.

3.4 Introduction to electric arc welding (AC & DC), practice in setting current & voltage for striking proper arc, precautions while using electric arc welding. Applications of arc welding. Introduction to polarity & their use.

3.5 Demonstrate & use of the different tools used in the welding shop with sketches, Hand shield, helmet, clipping hammer, gloves, welding lead, connectors, aprons, goggles, etc.

3.6 Demonstrate of welding defects & various types of joints & end preparation.

Job: Preparation of lap joint by arc welding rod. Job: Preparation of Tee joint by arc welding.

**Job: Preparation of single V or double V butt joint by electric arc welding.**

**Job: Brazing practice. Use of Spelt or (on MS sheet pieces).**

**Job: Gas welding practice on worn-out & broken parts.**

## **4. TURNING SHOP**

4.1 Introduction.

4.2 Safety precaution & safety equipments.

4.3 Various marking, measuring, cutting & holding tools.

4.4 Demonstration of different parts of a lathe, demonstration on centering & turning operation in a group of 06 students.

**Job: plain turning, taper turning & grooving practices on round bar.**

## **5. EXPOSURE TO C.N.C MILLING / LATHE MACHINE**

# SAFETY PRACTICE

## INTRODUCTION:

It's generally recognized that there is no machine or industrial or consumer product that cannot somehow be involved in an "accident" or "injury". "Safety" is a judgment of the acceptability of danger, where danger is the combination of hazard and risk. Thus, the safety of a machine or workshop depends on the hazard and risk involved with machine operation. Hazard is the likelihood that an injury will occur.

**The causes of injury are varied, but they involve the following factors such as :**

- a. Having part of the body caught in or between machine components.
- b. Being struck by an object.
- c. Falling from equipment, structures, or ladders.
- d. Slipping or tipping on floor surfaces.
- e. Explosions and fire.
- f. Exposure to high voltage electrical wiring and switch box.
- g. Burns with or exposure to temperature extremes.
- h. Exposure to or injection of toxic chemicals.
- i. Excessive physical strain.
- j. Protection of eyes from metal chips.

In United States, various safety and health standards have been promulgated by the American National Standards Institute. Safety literature is available from the National Safety Council.

**Safety professionals and organization have created the following hierarchy for treating hazards in the workplaces such as :**

- a. Reduce the danger to a reasonable level through design.
- b. Apply safeguarding technology.
- c. Use warning signs and label.
- d. Train and instruct the workers.
- e. Prescribe personal protective safety equipment (goggles, apron, shoes etc.)

All workshops and work-areas are places of some risks, but a healthy regard for the Rules and respect for the equipment being used reduces the risk of an accident considerably.

**The following are the golden rules of safe work-practices such as :**

- a. If you open it, close it.
- b. If you turn it 'ON', turn it 'OFF'.
- C. If you unlock it, lock it.
- d. If you break it, repair it.
- e. If you can't fix it, call in someone who can.
- f. If you make a mess, clean it up.
- g. If you move it, put it back.
- h. If it doesn't concern you, leave it alone.

**SAFE GUARDING METHODS:**

**Barrier Guards:**

- i. Provision of proper fencing around dangerous/ hazardous activity center.

**Safety Devices:**

- i. Pull-back mechanism for the operator's hands.
- ii. Dead-man Controls – A system in which the power is automatically shut off in the event of operator becoming senseless or collapsed.
- iii. Presence of sensing devices.

**Safety During Maintenance of Machinery:**

Normally, safety devices are temporarily removed during maintenance. It's the Employer/ Manager's responsibility to ensure. The maintenance personnel are competent to interact with the types of hazards expected and supposed to perform the maintenance in a safe manner. The maintenance staff should be familiar with safety practices related to their activities.

**Warnings:**

Sign Post, signals and instruction charts warn the worker about sudden hazards, danger control methods, or non-obvious consequences. The format, size, color of warnings has been prescribed by Industry Standards and ISI codes.

### **Personal Protective Equipment:**

Goggles, face-shields, earplugs, helmets, respirators, gloves and aprons are types of personal protective equipment that reduce worker's exposure to hazards.

### **SAFETY IN WORKSHOP:**

The first duty of the Manager or Instructor in a workshop is to brief a student or worker about various safety features and make them aware of various safety precautions to be observed while working on a particular machine/ machine tool. They should be sufficiently briefed about causes/ sources of injury or accidents and how to guard against them.

#### **Some of the Common Sources of Accident in Workshop are as Following:**

- a. Revolving parts like shafts, spindles, tools etc.
- b. Projecting sharp edges of belt/ chain/ pulley joints/ fasteners etc.
- c. Revolving parts like gears, rollers, friction wheels, drum, crushers etc.
- d. Continuously rotating parts like fans, open-arm pulleys, gear trains etc.
- e. Conveyors and mixers.
- f. Grinding wheels and stones.
- g. Reciprocating parts/ tools.
- h. Intermittent feed mechanism.
- i. Moving cranes/ trolleys/ welding machines.
- j. Bare cables, joints, switches, switchboard etc.

### **COMMON METHODS OF PROTECTION IN A WORKSHOP:**

**Some Common Methods of Protection in a Workshop are Discussed Given Below :**

#### **By Design :**

When a new machine is designed, suitable housing should be designed as safety guards.

**For Example:** i. Belt Drive/motor in a lathe or milling machine are enclosed in a housing.

ii. All control panels/handles should be carefully located to ensure adequate safety.

#### **By Position:**

A machine should be designed in such a way that the dangerous parts are located beyond the reach of the operator. They should be well-guarded also. The guards should form an integral

part of the machine or they should be tightly secured and should not be easily removable. They should be robust and rigid. Guards can also be automatic/ distant/ trip guards.

**Interlock Guards:**It ensures guards not be removed or the machine cannot start without the guards in position.

### **SAFETY FOR JOB :**

Production or repair of a machine or any part of a machine costs a lot of money. If we do a job carelessly it would further increase its cost. Therefore, it is also essential that one should do the job with due care and precautions for safety. The following safety measures are necessary to ensure safety for job as follows:

- i. Before taking any job in the workshop, it is necessary to plan the operation of work and job should be performed accordingly otherwise it may result in loss of time and and money and the job would not be done satisfactorily.
- ii. If a machine is required to be used for doing a job, it should be ensure that job is carried out properly on the machine.
- iii. While cutting a particular object one should not make a deep cut.
- iv. Proper tools, with sharp edges, should be used for cutting jobs otherwise it would spoil the job.
- v. Proper arrangements should be made to fasten heavy jobs on machines.
- vi. Use of right types of tools and machines for various job is very important for proper results.

### **IMPORTANT POINTS REGARDING FIRST AID:**

- i. We should not get nervous at the sight of patient's injury of pain.
- ii. Instead of going into the questions of how the accident occurred, when it happened and why it happened,we should immediately arrange to provide First Aid to the patient.
- iii. We should check up properly how much pain the accident - victim is feeling and where.
- iv. If the patient is unconscious and blood is coming out, immediate steps should be taken to stop it.
- v. It should be ensured that crowd does not gather around a patient.
- vi. An accident patient can be given hot milk or tea but not water or intoxicating things.
- vii. If an accident victim has got burn injuries, he/she should not be allowed to remain in open air but ablanket should be wrapped round his/her body.
- viii. We should be arrange to call a doctor immediately or try to carry the accident victim to a doctor, if the situation so demands.

# FITTING SHOP

## INTRODUCTION:

Components may be produced by working on metal either on a machine tool or on the bench. Sometimes it becomes necessary to replace or repair a component which must fit accurately with another component on re-assembly. This involves a certain amount of hand fitting. The assembly of machine tools, jigs, gauges, etc. involves a certain amount of bench work. The accuracy of work done depends upon the experience and skill of the fitter. Metal removal at the bench requires the use of a number of simple hand tools and considerable manual effort. Working on components with hand tools and instruments, mostly on work benches is generally referred to as, 'Fitting Work'. The hand operations in bench work consist of filing, chipping, scraping, sawing, drilling, tapping, grinding etc.

## HOLDING DEVICES:

The holding tools or vices are required to hold the work firmly. Following are the various types of vices for different purposes.

1. **Bench vice** -It is used for holding the work and is firmly fixed to the bench with bolts and nuts. It consists of an iron or steel cast body, square threaded screw, nut, handle (made of mild steel), two jaws and jaw plates (made of cast steel). One of the two jaws is stationary, while the other jaw is movable which can be brought close on the work by rotating the square threaded screw in the nut. The jaws plates are knurled on one side and fixed in the jaws with the help of screws and can be replaced when worn out. The knurling is done to help in gripping the work. For holding soft material or finished work, soft plate liners or coverings made of lead, fiber, copper, brass or tin plate are fitted over the jaws for giving protective grip in order to prevent the surface of the finished work from damaging

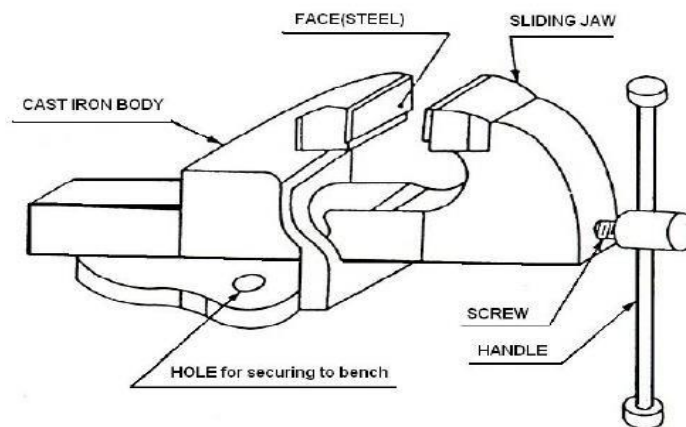

Fig 1.1. Bench Vice

2. **Hand vice** - It consists of two jaws and hands which are hinged together, on a pivot, on the opposite ends. The work is held in between the serrated faces of the jaws with a screw and a wing nut. A flat spring, fixed between the two hand jaws, helps open them out by its pressure.



The vice is held in one hand and the required operation is performed by the other hand. It is used for gripping small objects such as screws, rivets, small drills, keys of locks and other similar objects which are too small to be conveniently held in bench vice.

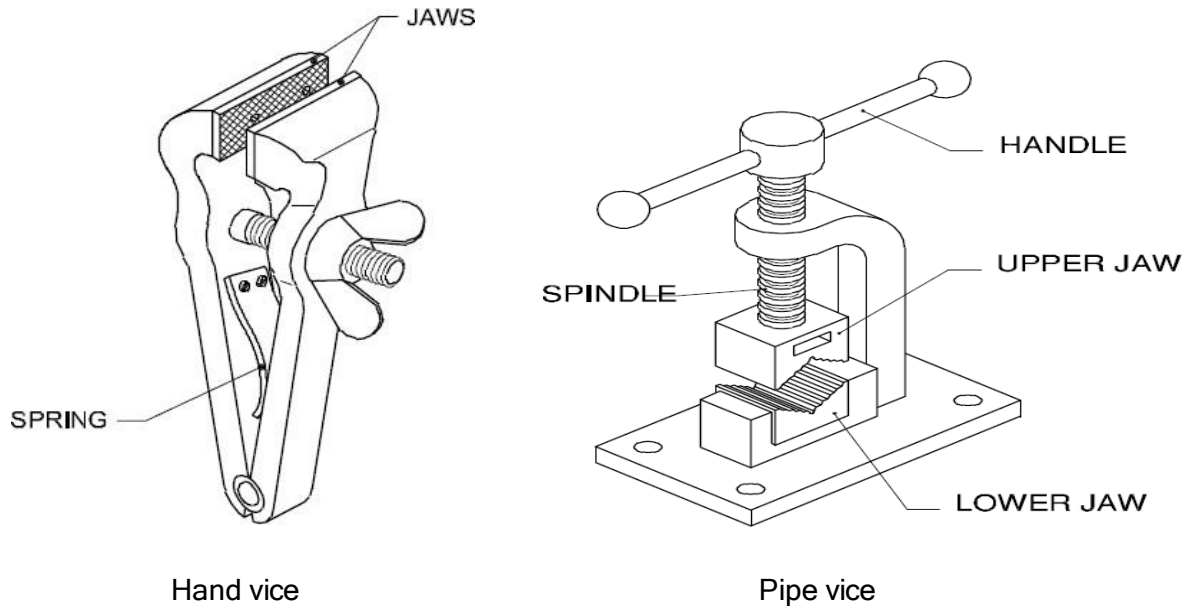

Fig 1.2

**3. Pipe vice** -It is used for holding pipes, shafts or round jobs. It works on the same principle as the bench vice. It consists of two jaws, one of which is fixed and the other is movable. The shape of the jaws is like a V and it grips the work at four points or its surface.

**4. Leg vice** - It is generally used in a smithy shop, but it is also suitable for heavy hammering, chipping and cutting in fitting shop. The vice is secured to the top of the bench by an iron strap which is fastened to a plate bolted to the bench top. It differs from the bench vice in that the movable jaw is pivoted about a point near the middle of the leg of the vice. This prevents the faces of the two jaws from being parallel to each other in every position except one position.

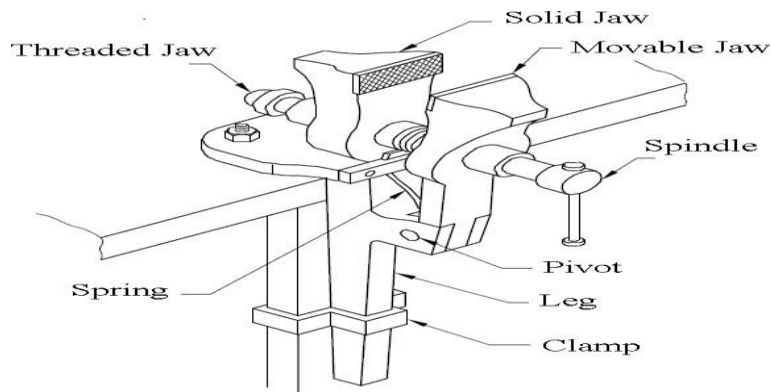
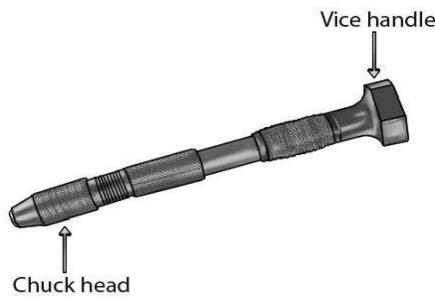
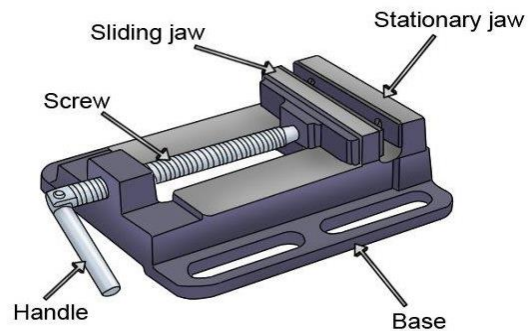

Fig 1.3. Leg Vice

**5. Pin vice** -This is a holding device for small diameter work, such as wires and pins. It consists of a fine self centering chuck on a handle which may be of wood or metal. The work is gripped between the jaws of the chuck by rotating the handle.



Pin Vice



Tool maker's vice

Fig 1.4

**6. Tool maker's vice**- It is particularly used for holding small work for filing or drilling. It is made of mild steel. It consists of a body with a solid jaw, a movable jaw, a screw and a handle for the control of movement of movable jaw

**CLAMPING DEVICES :**

**Mechanical Clamping**

**1. Screw Clamping -**

These are simple clamps where torque developed in a screw thread is used to hold the work piece. It can be direct or indirect. There are different holding forces for different screw sizes.

**2.C-Clamps –**

A C-clamp or G-clamp or G-cramp is a type of clamp device typically used to hold a wood or metal work piece, and often used in, but are not limited to, carpentry and welding. Often believed that these clamps are called "C" clamps because of their C-shaped frame, or also often called C-clamps or G-clamps because including the screw part, they are shaped like an uppercase letter G.

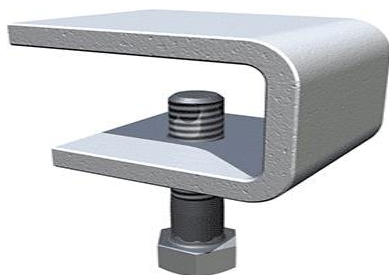

Screw clamp



C clamp

Fig 1.5

### 3. Strap Clamps –

The basic operation is same as that of a lever. It can be classified into 3 based on the position of work piece(work),support(fulcrum) and fastener screw(effort).

### 4. Swing Clamp –

Swing clamp has a screw clamp with swinging arm that pivots on its mounting stud.

### 5. Latch Clamp –

Latch clamp is known for its advantage in the speed of manipulation. It is limited to light work as it is difficult to secure rigidly.

### 6. Pivoted Clamps –

Clamps are often pivoted at the center to simplify their operation. Tightening and loosening is done using knurled head screw.



Fig 1.6

## TOOLS AND EQUIPMENT REQUIRED IN FITTING SHOP:

Both the bench work and fitting require the use of a number of simple hand tools.

### Marking and Measuring Tools :

#### STEEL RULE :

When dimensions are given in drawing without any indication about the tolerance, it has to be assumed that measurement are to be made with a Steel Rule, which is used for measurement of length. It is usually graduated in millimeter and inches. Its least count is 0.5 mm or 1/64 of an inch. Steel Rules are made of spring steel or stainless steel. The surface of the steel rule is stain - chrome finished to reduced glare and to prevent rusting.

#### Measuring with a Steel Rule :

The given figure indicates the method of using a try square and a steel rule for accurate measurements. It is necessary to read vertically and avoid errors arising out of parallax for accurate readings. The steel rule graduations are accurately engraved, with line thickness ranging from 0.12 to 0.18 mm.

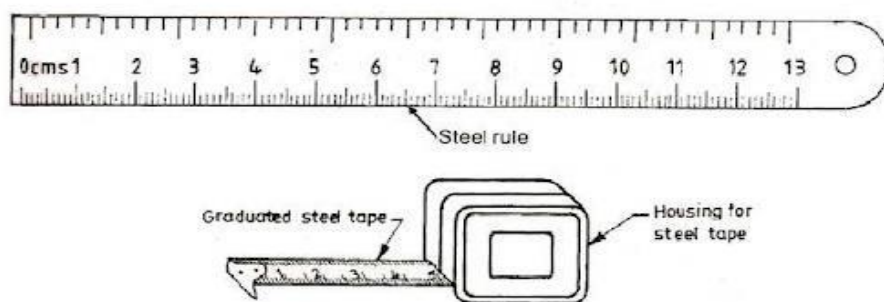

Fig 1.7.Measuring Tape

#### PRECAUTIONS:

- a. For maintaining the accuracy of a steel rule, it is important that to see it that its edges and surfaces are protected from damage and rust.
- b. Do not place a steel rule with any cutting tools.
- C. Apply a thin layer of oil when not in use.

#### FILES:

A file is a hardened piece of high grade steel with slanting rows of teeth. It is used to cut, smooth or fit metal parts. It cuts all metals except hardened steel and it cuts only on the forward stroke. It consists of a blade or body with a tang for fixing into the wooden handle. The teeth are

cut on the blade which are hardened and tempered. The tang is tempered to make it soft and tough. The various parts of the blade. The metal ring on the file handle is called ferrule, in order to prevent splitting of the handle. The files are classified according to the size, cut of teeth, grade and shape or cross-section of the file as discussed below

**(a) Size of file**-The size of the file is indicated by its length. It is the distance from the point to the heel without tang. The length of the file, in general use, is 200 mm to 450 mm and 100 mm to 200 mm for finer work.

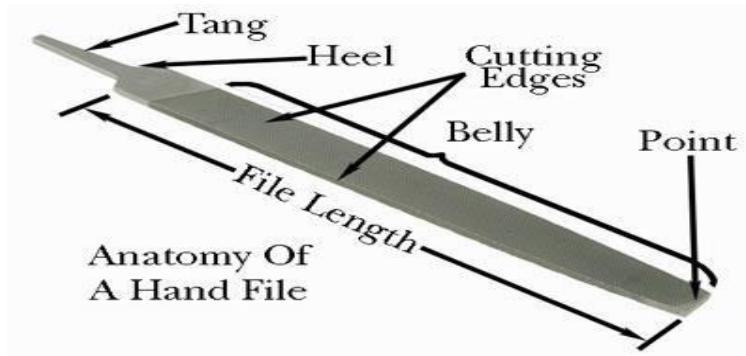

Fig 1.8.File

**(b) Cut of teeth**-The files, according to the cut of teeth, are divided into two groups, i.e., single cut and double cut.

In single cut files, the teeth are cut parallel to each other running across the faces and at angle of  $65^{\circ}$ - $70^{\circ}$  to the center line of the file. These files are frequently termed as flats and are particularly used for very hard metals.

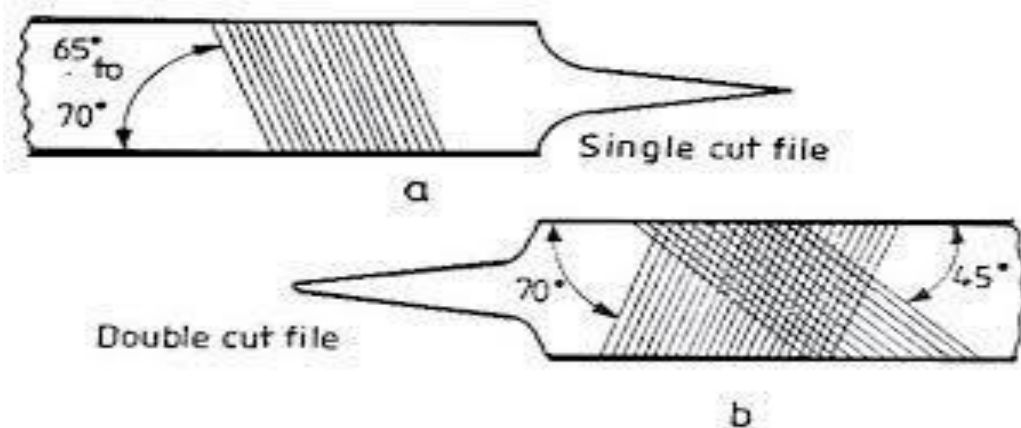

Fig 1.9.Double cut and Single cut file

In double cut files, there are two sets of teeth. The first set of teeth are similar to those of single cut files (i.e., at  $70^{\circ}$  to the center line of the file) while the second set of teeth are cut diagonally

across the first set of teeth at an angle of about  $45^\circ$  to the center line of the file. All the teeth have negative rake i.e., sloping backwards by which they cut only on the forward stroke. It removes metal faster and is used for general work.

**(c) Grade of cut of file** -The single cut and double cut files, depending upon the pitch of the teeth (i.e., spacing between the rows of teeth) may be classified as rough (R), bastard (B), second cut (SC), smooth (S), dead smooth (DS) and superfine or super smooth (SS).

**(d) Shape of files**-The files, according to their shape or cross-section, are classified as discussed below:

**1. Flat file.** A flat file is parallel for about two-thirds of its length and then tapers in width and thickness. It has double cut on both faces and single cut on both edges. It is mostly used for general work and for filing flat surfaces.

**2. Hand file.** A hand file, has its width parallel throughout, but its thickness tapers. The both faces are double cut and one edge single cut. The uncut edge is called the safe edge and prevents cutting into one face of a square corner while the other face is being filed. It is used for general surfacing work, more particularly for filing steps or shoulders to square work without touching and spoiling the adjacent surface, already made true.

**3. Square file.** A square file is parallel for two-thirds of its length and then tapers towards the tip. It is double cut on all sides and is used for filing square corners and slots. CUT

**4. Pillar file.** A pillar file, is similar to hand file, but is narrower and thicker than hand file. It has one or both uncut edges (i.e., safe edges) and is used for narrow work such as keyways, slots and grooves.

**5. Triangular file.** A triangular file, has width either parallel throughout or up to middle and then tapered towards the tip. Its cross-section is triangular (equilateral) and the three faces are double cut and edges single cut. It is used for filing square shoulders or corners and for sharpening wood working saws.

**6. Round file.** A round file, has round cross-section. A file with width parallel throughout is called parallel round and the file with width parallel up to middle and then tapering towards the tip is called rat file. The round files are usually double cut on the Rough and Bastard qualities over 15 cm long while the Rough and Bastard under 15 cm, together with second cut and smooth, are single cut. The round files are used for opening out holes, producing round corners, round-ended slots etc.

**7. Half round file.** The section of a half round file is not a true half circle but is only about one-third of a circle. The width of the file is either parallel throughout or up to middle and then tapered towards the tip. The flat side of this file is always double cut and curved side has single cut. It is used for filing curved surfaces.

**8. Knife edge file-**A knife edge file has a width tapered like a knife blade. It is also tapered towards the tip and thickness. It is double cut on both flat faces and single cut on both edges. It is used for finishing sharp corners of grooves and slots.

**9. Warding file-** A warding file is similar to flat file but it is thinner and parallel on its thickness. It is used for filing narrow slots.

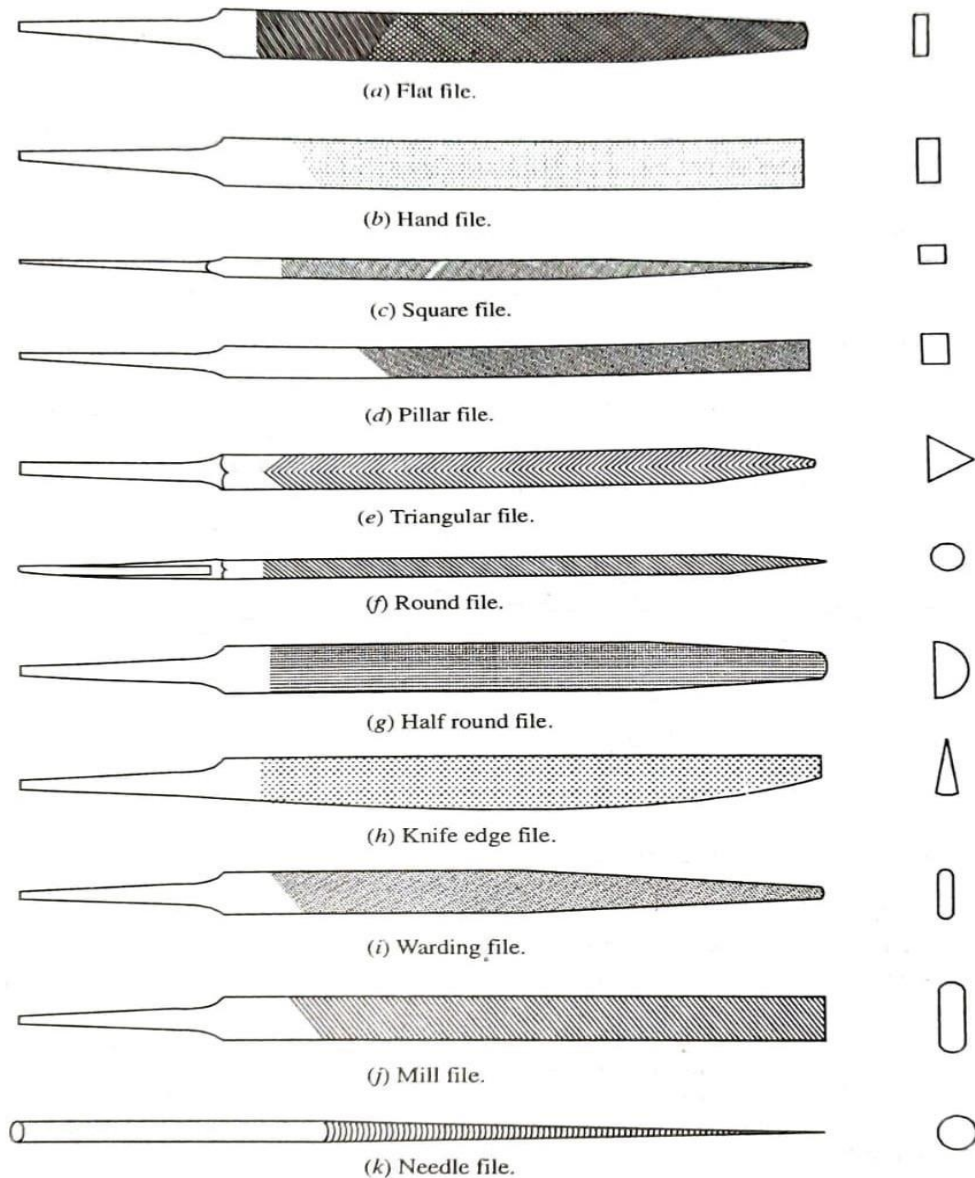

Fig 1.10. Various Types of File

**10. Mill file -** A mill file is similar to flat file but parallel on both width and thickness and have both edges round, It is single cut and is suitable for forming the radius on saw teeth and in slots.

**11. Needle files-**The needle files are available in sizes from 100 mm to 200 mm of various shapes and cuts. These files are used for fine work such as pierced design in sheet metal

### **Filing-**

Filing is required after chipping or cutting operation to remove burr and clean the face of the cuts and to finish the final shape of the work piece. It may be noted that not more than 0.6 mm should be left for filing. The filing operation consists of the following steps :

1. The work should be held firmly in the vice with the minimum amount of projection and with the surface to be filed truly horizontal.
2. The file handle is grasped in the right hand and the end of the file handle pressing against the palm of the hand. The pressure on the work is applied by holding the end of the blade with the left hand. The worker should take his position on the left side of the vice with the feet firmly planted, slightly apart.
3. A stroke should be made by a slight movement of the right arm from the shoulder and by a sway of the body towards the work, each of these movements being about equal.
4. The file must remain horizontal throughout the stroke (which should be long, slow and steady) with pressure only applied on the forward motion.
5. The file on the return stroke remains in contact with the work but the pressure is relieved from it.
6. In order to test the surface of work during filing, a straight edge should be placed on it occasionally and the line of contact is viewed for day-light. When any considerable amount of metal has to be removed, the bulk of it should be removed by a rough or bastard-cut file and the surface progressively brought to a finish by second-cut and smooth files.

### **Method of Filing**

The following three methods are commonly used for filing :

- 1. Cross-filing.** It is the most common method of filing for general shaping work. It is used for efficient removal of maximum amount of metal in the shortest possible time. In this method, the filing strokes run alternatively from left to right and from right to left so that whole of file surface moves across whole of work surface in one stroke. In cross-filing the possibility of rounding of surface is less and the scratch marks of the file teeth cross each other so that maximum amount of metal is removed.
- 2. Straight filing.** It is specially useful on long and narrow pieces of work whose width is less than that of the file. In this method, the file stroke is made nearly at right angles to the length of work.
- 3. Draw filing.** The draw filing is used to remove file marks and for finishing operation. During this operation, the file is gripped as close to the work as possible between two hands. It is



moved lightly to and fro over the work. For this purpose, a fine cut file with a flat face (e.g., mill file) should be used.

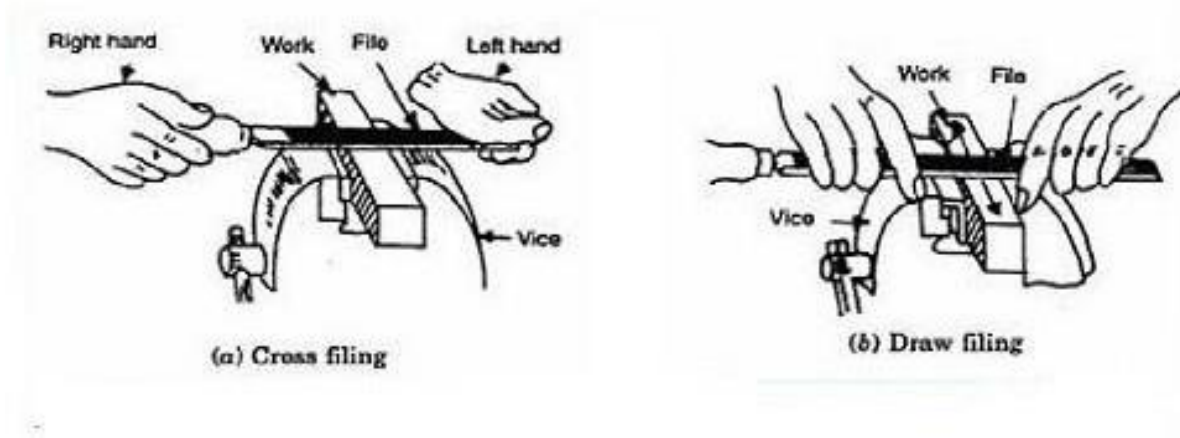

Fig 1.11.Methods of Filing

## Cutting Tools

The chief cutting tools used in fitting are cold chisels, hacksaws and files. These are discussed in detail.

## Types of Chisels

The various types of chisels commonly used for fitting are as follows:

### 1. Flat chisel.

A flat chisel is the most common of all the chisels. It has a wide cutting edge about 16 mm to 32 mm and is slightly rounded to prevent the corners from digging into the metal. The length of the chisel varies from 100 mm to 400 mm. It is used for chipping flat surfaces, cutting off sheet metal, cutting bars and rivets.

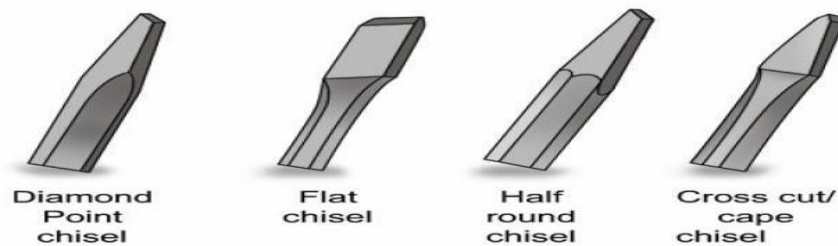

Fig 1.12.Types Of Chisels

## 2. Cross-cut chisel or cape chisel.

A cross-cut or cape chisel has a cutting edge about 4 mm to 12 mm wide. From the edge, the metal thickness tapers off slightly. This is to permit the chisel to clear when a groove is being cut. It is widely used for cutting grooves in large surfaces before using the flat chisel. It is also used for cutting keyways in wheels and shafts.

## 3. Half-round chisel.

A half-round chisel has a semi-circular cutting edge. The width of the cutting edge varies from 2 mm to 16 mm and length varies from 150 mm to 250 mm. It is used for cutting round or semi-circular oil grooves in bearings, bosses and pulleys.

## 4. Diamond pointed chisel.

A diamond pointed chisel has a cutting edge shaped like a diamond. The width of the cutting edge varies from 6 mm to 16 mm and length varies from 100 mm to 400 mm. It is used to cut V-grooves and to chip square corners.

## PUNCH

Punch is a marking tool used in order to make certain dimensional features of the layout permanent. Basically, there are two types of punches such as : Dot and Centre Punch

### Centre Punch:

Centre Punch is made of high carbon steel. The angle of the point is  $90^\circ$  in a centre punch and the punch mark made by this is wide and not very deep, which is particularly used for locating holes. Its length is from 35 mm to 125 mm. and its width is from 4 to 12 mm. If this centre is not made by the centre punch, then there are chances of slipping of the point and drilling at a wrong point, which is shown as the given figure.

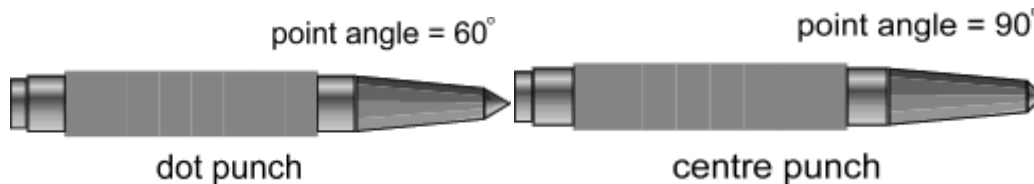

Fig 1.13

fig 1.14

### Dot Punch :

Dot punch is used in order to lightly indent along the layout lines to locate centre of holes and to provide a small centre mark for divider point etc. The main difference is that its point is at  $60^\circ$  Angle. Its length is from 80 mm to 100 mm. and its thickness from 3 mm to 5 mm. which is shown as given figure. There are also different types of punches are available such as : Solid, Hollow, Pin, Bell, Prick and Automatic Punch.

### PRECAUTIONS :

- a) Do not use an ordinary punch or a hard metal.
- b) Use a punch after seeing its angle.
- c) If the point of the punch is damaged, then it should be repaired and the punch should be used
- d) Selection of punch should be made according to the make-up of the job or metal.

### SCRIBER:

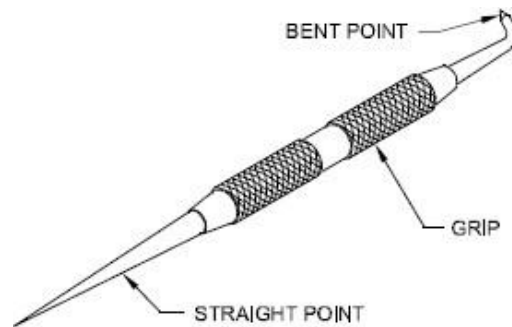

Fig 1.15.Scriber

A scribe is a slender steel tool used to scribe or mark lines. It is made of steel or high carbon steel wire of 3 mm to 5 mm, whose one end is straight and the other is bent at about 90° Angle. Its length varies from 150 mm to 300 mm. Both its ends are pointed. There are Five types of Scribes are available as follows : Ordinary, Improved, Adjustable Sleeve, Pocket and Knob Scriber.

### PRECAUTIONS:

- a. Scriber points are very sharp, and they are to be handled very carefully.
- b. Do not put the scriber in your pocket.
- C. Place a cork on the point when not in use to prevent accidents.

### HAMMER:

Hammer is a striking tool, which is used to beat or striking blows on jobs or metals or for driving rails etc. It is also used to straighten or bend a job made of metal. In addition it is also used for riveting, chipping and forging jobs and also used to cut hard wires with the help of a chisel as shown in the figure. There are the following types of hammers are used in engineering fields such as : **Ball Pane Hammer, Cross Pane Hammer, Claw Hammer and Soft Harmer**. Hammers are named depending on their shape and material and specified by their weight. A ball peen hammer has a flat face, which is used for general work and a ball end, particularly used for riveting.

## V-BLOCK:

V-Block is a rectangular block, which has a 'V' shaped groove on its upper surface which is shown in the given figure. The angle of the 'V' is during layout of measurements or for measuring operations. Heavy round jobs are kept over it for marking. There is no provision to clamp the job since because of heavy weight of the job, it remains fixed.

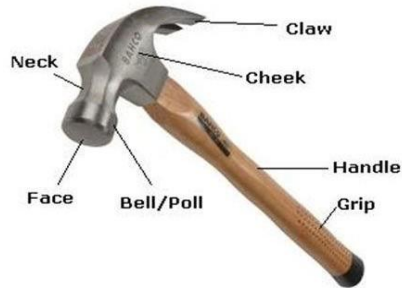

Fig 1.16.Claw Hammer

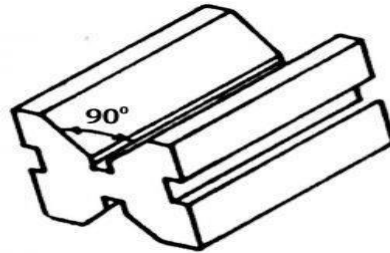

fig 1.17.V-Block

## TRY SQUARE:

Try Square as shown in fig 1.18 is used for measuring right angle of a job and for checking squareness of many types of small works. The blade is made of hard steel and the beam of steel. It is actually used to check whether the angle made by the two sides of square is a right angle (90°) or not.

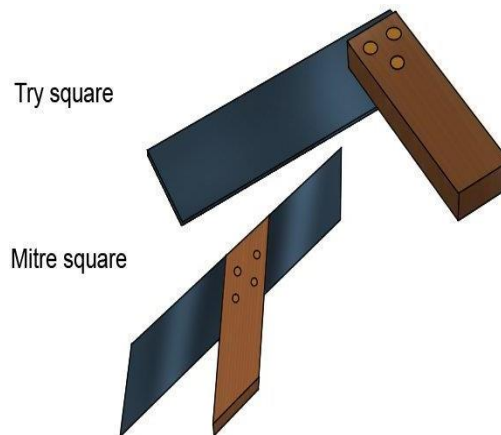

Fig 1.18.Try Square and Mitre Square

## PRECAUTIONS:

- We should not use try square as a hammer i.e. we should not use it to hit any job otherwise its accuracy is spoiled.
- Try square should be kept away from cutting tools.
- It should be cleaned properly before use.

d. After making its use, it should be kept after applying grease.

### **SURFACE PLATE:**

Surface Plate is used for marking purpose. The job is placed over the surface plate and marked with the help of bevel protractor. It is made of cast iron. It is usually rectangular in shape.

### **PRECAUTIONS:**

- a. Before marking or measuring a job, its surface should be properly cleaned with a soft paper.
- b. While using it, it should not be hit as there are chances of damage to its surface.
- c. In order to make the marking of the job permanent it should not be used as a table.
- d. Cutting tool should never be used on it.

### **ANGLE PLATE:**

Angle Plate is placed over the surface plate for supporting jobs at the time of marking. It is made of cast iron. The angleplate is built at  $90^\circ$  Angle, which has rectangular grooves. Both its outer surfaces are accurately plained by the scraper. In case of heavy jobs, nut bolts are fitted in its grooves and marking is done. Angle plate is of two types such as : Fixed angle and Adjustable angle plate.

### **PRECAUTIONS:**

- a. Angle plate should be carefully handled and maintained.
- b. Any nicks or scratches can spoil the accuracy of the angle plates.
- c. In order to make the marking of the job permanent it should not be used as a table.

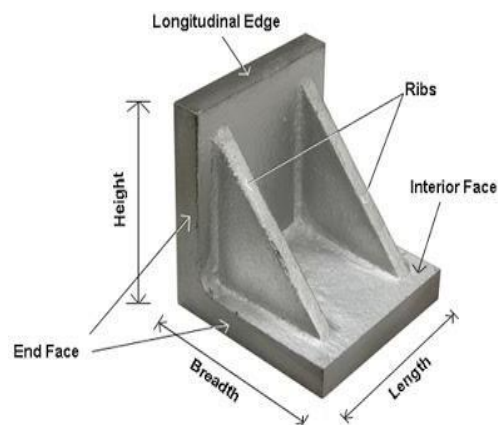

**Angle Plate**

## OUTSIDE CALIPER :

The caliper whose leg bent toward the centre is called Outside Caliper. It is used to measure the outside diameter of a cylinder, bar etc. It is also used for transfer dimension one place to another place by the help of steel rule.

## INSIDE CALIPER :

The Caliper whose leg forward to the centre is called inside caliper. It is used to measure inside diameter of a hole, bore, slot etc. It is also used for transfer dimension one place to another place by the help of steel rule.

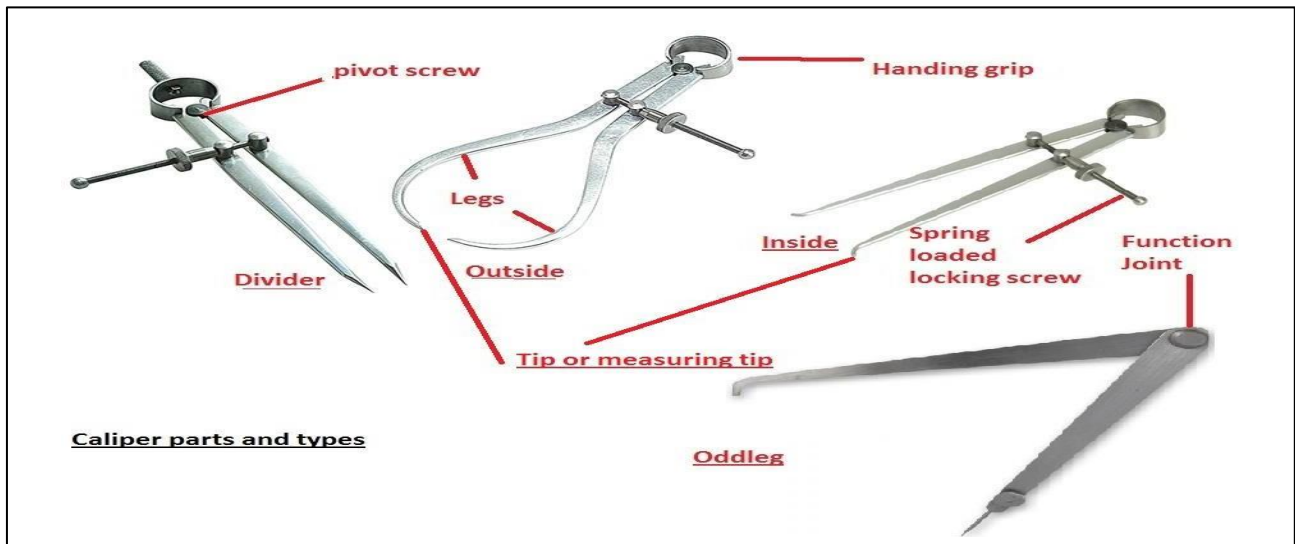

Fig 1.19. Various Types Of Calliper

## Steel Tape :

Steel Tape is measuring instrument, which is used to measure length, breadth and thickness of a job.

## Spirit Level :

Spirit Level is used for testing the levels of flat surface

## Straight Edge :

This tool is used for testing the straightness and flatness of plane surfaces

## Dividers :

Dividers is used for marking circles, arcs, laying out perpendicular lines, bisecting lines etc

## COMBINATION SET :

Combination Set is a very useful instrument having a combination of five different instruments in one. A combination set consists of a rule, square head, centre head and a protractor. This may

be used as a rule, a square, a depth gauge for marking degrees ( $45^\circ$ ) and for locating the measuring and marking angles.

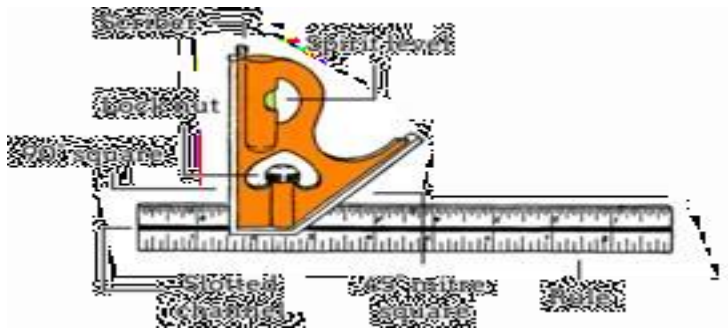

Fig 1.20. Combination Set

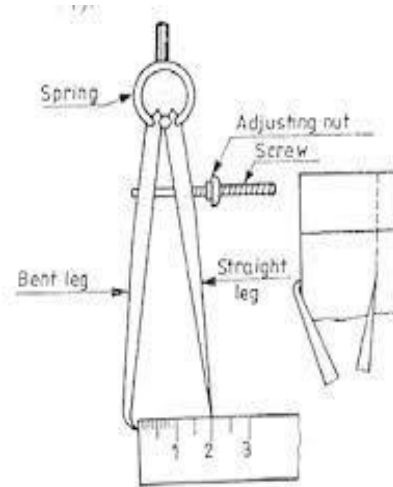

Fig 1.21. Divider

### VERNIER CALIPER:

Vernier Caliper is a precision measuring instrument used for measurement of outside diameter, inside diameter and depth. The least count of vernier caliper is 0.001 inch and 0.02 mm. Vernier caliper is made by assembling several different parts as shown in the given figure.

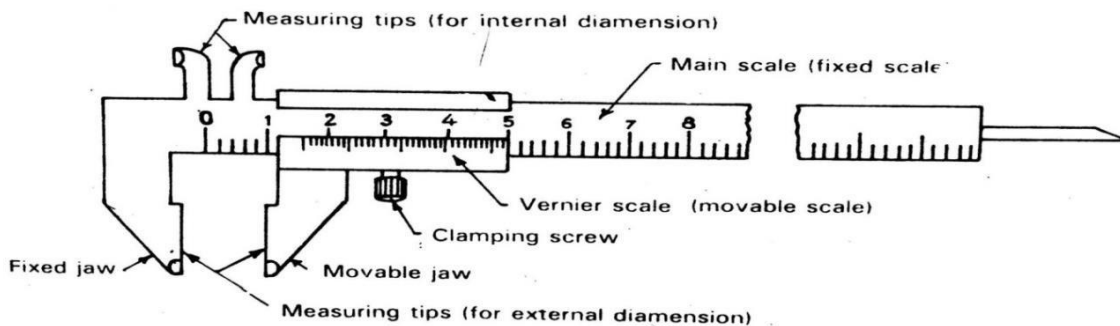

Fig 2.22. Vernier Caliper

### METHOD OF TAKING READING:

- a. Write that part of the scale which contains inch signs and which is on the left hand side of 0, on the vernier scale.
- b. Look at the divisions of central distance. How many of them are on the left hand side of 0 of the vernier? Their value is 0.1 and 0.2 inch, respectively.
- c. Write the small parts of the main scale. Their value is 0.025.

d. Write down the part of the vernier scale which corresponds with the main scale after carefully watching it.

e. The sum total of all the four items written above is reading of the vernier caliper.

#### PRECAUTIONS:

a. It is necessary that there is no play in its beam and movable jaw and it could be easily

b. After long use, the jaw-edges wear out. In such cases, it should be regrinded.

c. A job fixed on a machine in operation should not be Scale measured with it.

d. It should always be kept away from the cutting tools.

e. It is difficult to see the part of scale. Therefore, it is advisable to use a magnifying glass.

f. After using it, we should clean it with thinner and keep it in the case.

#### VERNIER HEIGHT GAUGE:

Vernier Height Gauge is similar to vernier calipers and used for marking purpose by the help of surface plate and angle plate. It consists of scribe by which lines are scribed on the job. In vernier height gauge, slide base remains joint with the beam permanently as shown in the figure.

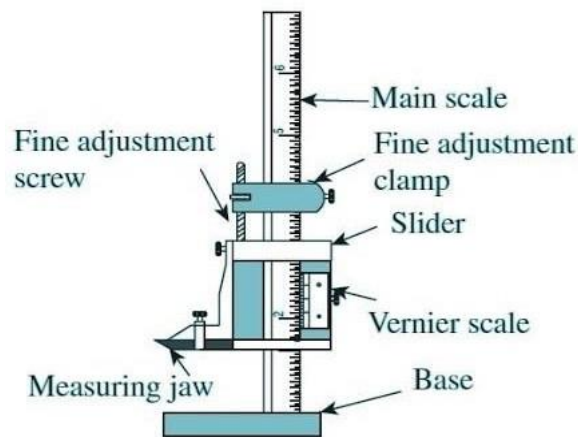

Fig 1.23. Vernier Height Gauge

#### PRECAUTIONS:

a. It should always be used on the plain surface of the job.

b. While marking, excessive pressure should not be exerted on its scribe.

c. It should be used on a surface plate only.



- d. It should be used only for precision marking or measurement.
- e. Its reading should be noted down.

**MICROMETER:**

Micrometer is a measuring instrument used for measuring external, internal and depth dimensions accurately. They are available in different ranges. It is made on the basis of nut and screw bolt. The different parts of the micrometer are given in the figure. There are Three types of micrometer such as: Outside, Inside and Depth Micrometer.

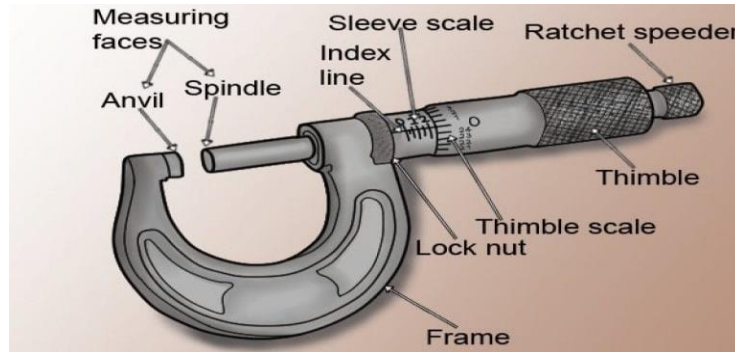

Fig 1.24.Micrometer

**PRECAUTIONS:**

- a. Before using it, it should be properly cleaned with a soft cloth.
- b. Before use, it should be ensured that it is faultless.
- c. It should not be used on machines in operation or on rough surface.
- d. Before measuring, job should be properly cleaned.
- e. For setting it Ratchet Stop should be used.
- f. After measuring, it should be locked and then reading should be taken.
- g. While keeping it, anvil and spindle should be separated.
- h. It should be saved from water.

**DEMONSTRATION OF VARIOUS OPERATIONS IN FITTING SHOP**

**A. SAWING OPERATION**

It is the cutting and slotting operation and performed as follows:

- 1. The work is held tightly in the vice.

2. A suitable blade is fixed with its teeth facing forward so that it cuts the material in the forward stroke. The blade is tensioned sufficiently by a wing nut.
3. The course of the desired cut is marked by a guide line on the work and a nick or notch is made with a file.

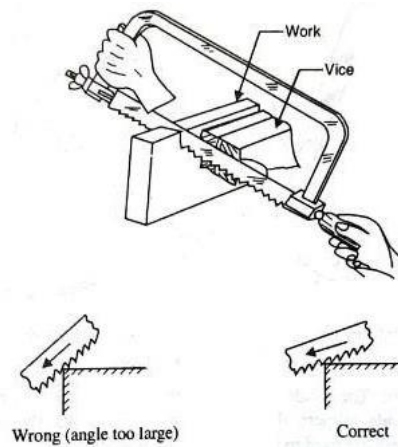

Fig 1.25. Sawing Operations

4. The frame of the hacksaw is held
5. Now the cutting is started at the neck by keeping the blade slightly inclined to the horizontal, as shown in Figure. The pressure is applied during the forward stroke and it should be relieved during the return stroke.
6. Material of blades:
  - HCS: High Carbon Steel
  - HSS: High Speed Steel

## B. CHIPPING OPERATION

The operation used for cutting or removing thick layers of metal by means of cold Chisels, is known as chipping.

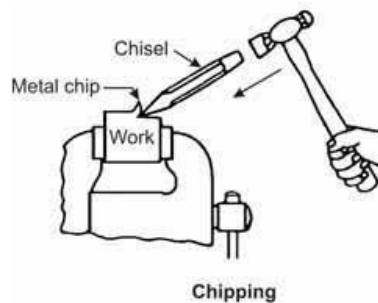

Fig 1.26. Chipping Operation

The chipping operation is carried out as follows:

1. The work is firmly held in a vice.
2. The chisel is firmly gripped in the left hand leaving some distance above the thumb of the hand as shown in Fig.
3. The hammer is grasped near the end of the hammer in the right hand. In operation, it should be brought up to the shoulder to ensure more power in the blows.

The following points should be kept in mind while chipping the surface.

- (a) The same cutting angle of the chisel must be maintained during the chipping operation.
- (b) If the surface to be chipped is very large, it is advisable to cut grooves along the whole surface by means of a cross-cut or cape chisel and then chip off the remaining metal.
- (c) When removing large amount of metal, it is necessary to lubricate the cutting edge frequently in order to have longer life of the chisel and to make chipping easier and smoother.
- (d) The operator who performs the chipping operation should always keep his eyes on the cutting edge of the chisel and not at the head.

## **FITTING OPERATION**

Fitting deals with the assembly of mating parts, through removal of metal, to obtain the required fit. Both the bench work and fitting requires the use of number of simple hand tools and considerable manual efforts. The operations in the above works consist of filing, chipping, scraping, sawing drilling, and tapping

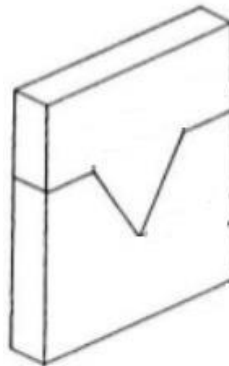

Fig 1.27. Male-Female Fitting

## **Marking**

The marking out operation consists of scratching of lines on the surface of a sheet metal. It is also called scribing operation. Before marking operation is carried out, the paper or metal pattern of the object is prepared. The metal pattern is desirable for repetitive work because it

maintains accuracy for a long time, whereas the paper pattern tears quickly if used repeatedly.

## GRINDING

The grinding is the process of removing metal by the use of grinding wheels. The work for grinding is pressed against the grinding wheel which rotates at a comparatively high speed and the surplus metal is removed by abrasion as shown in figure 1.28. It produces extremely smooth finish due to the small cutting edges on the wheel. It can finish work to very accurate dimensions in a short time.

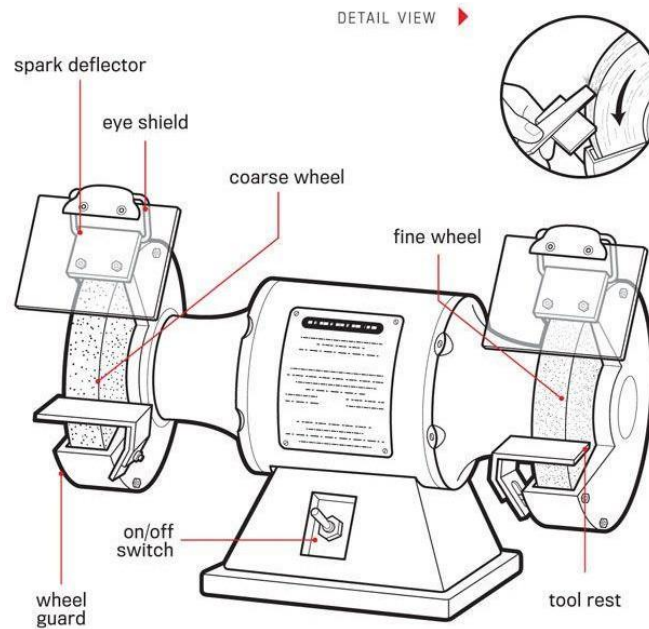

Fig 1.28.Grinding Machine

## REAMING:

It is the process of making a hole smoothly and accurately by the tool called reamer. Reaming is a cutting process that involves the use of a rotary cutting tool to create smooth interior walls in an existing hole in a work piece. The rotary cutting tool used in reaming is known as a reamer. Like drill bits, reamers also remove material from the work piece on which they are used. However, reamers remove significantly less material than drill bits. The primary purpose of reamer tool as shown in fig 1.29 is simply to create smooth walls in an existing hole.



Fig 1.29.Reamer

## TAPPING:

A tap is a screw-like tool which has threads like a bolt and three or four flutes cut across the thread. It is used to cut threads on the inside of a hole, as in a nut. The edges of the thread formed by the flutes are the cutting edges. The lower part of the tap is somewhat tapered so that it can well dig into the walls of the drilled hole. The upper part of the tap consists of a shank ending in a square for holding the tap in the machine spindle or by a tap wrench

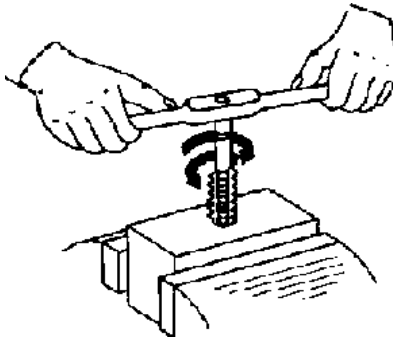

(Tapping operation)

Fig 1.30

## DRILLING

Drilling operation as shown in fig 1.31 is a cutting process that uses a drill bit to cut a hole of circular cross-section in solid materials. The drill bit is usually a rotary cutting tool, often multi-point. The bit is pressed against the work-piece and rotated at rates from hundreds to thousands of revolutions per minute.

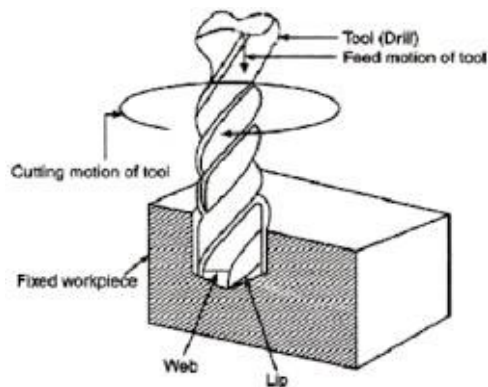

Fig 1.31. Drilling Operation

The operation of making round holes in metal pieces is known as drilling. It is done with the help of a drilling machine. There are many types of drilling machines, but the most common drilling machine used in fitting shop is a vertical drilling machine.

The drilling operation is carried out as discussed below:

1. First of all, the work is marked with a centre punch at the centre of the hole to be drilled
2. It is then firmly held in a vice or other suitable clamping device and placed on the adjustable table of the drilling machine.

3. The drill is fitted in the chuck.
4. The spindle with the chuck is lowered by the hand lever and it is ensured that the point of the drill is in exact alignment with the previously marked. centre of the hole
5. The motor is now started and the rotating drill is gradually pressed into the work to produce the desired hole.
6. The pressure should be frequently relieved during the drilling operation, otherwise the cutting edges of the drill will be strained and the drill is damaged.
7. In order to avoid the spoiling of cutting edges of the drill, a coolant such as oil or soap water should be used constantly during the drilling operation. The coolant is not required while drilling in brass and cast iron.

### **SCRAPPING:**

The process of removing metal with a scraper to obtain a true flat surface, is known as scraping. Before scraping, it is necessary to establish the high spots or impressions on the work which require scraping. This is done by moving the surface of the work to and fro on the surface plate, top of which is covered with a thin film of Prussian blue or red lead. The high spot marked on the surface of the work are now scrapped down by a scraper.

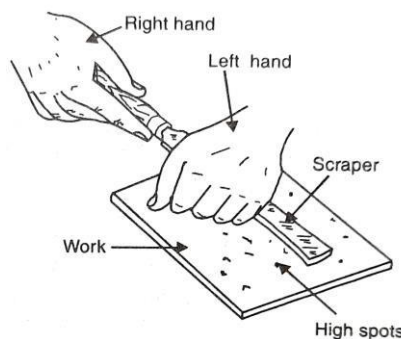

Fig 1.32. Scrapping Operation

**Care of Scraper** Since the scrapers have a very sharp cutting edges, therefore, when these are not in use it is advisable to keep them lightly oiled and individually wrapped in a piece of cloth or felt or semi material, to protect the extremely hard cutting edge.

### **TAPPING:**

A tap is a screw-like tool which has threads like a bolt and three or four flutes cut across the thread. It is used to cut threads on the inside of a hole, as in a nut. The edges of the thread formed by the flutes are the cutting edges. The lower part of the tap is somewhat tapered so that it can well dig into the walls of the drilled hole. The upper part of the tap consists of a shank ending in a square for holding the tap in the machine spindle or by a tap wrench

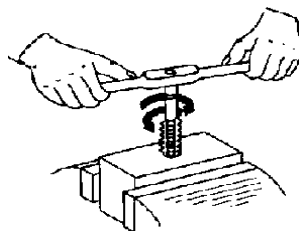

Fig. 1.33. Tapping

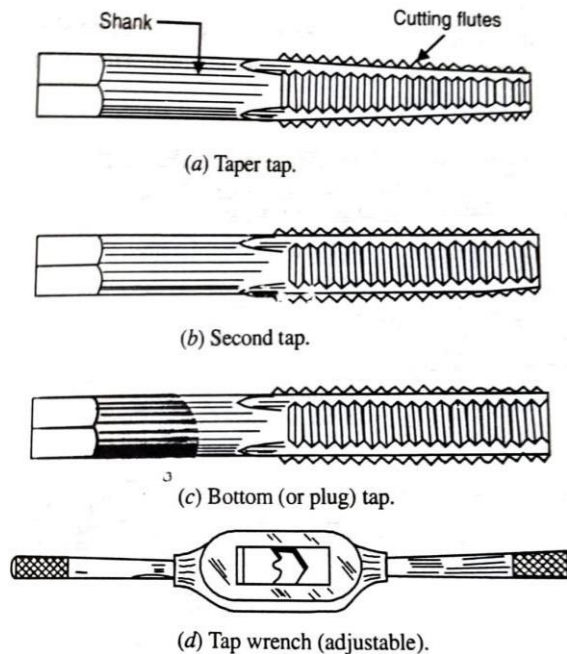

Fig. 1.34 Various types of Taps

The process of cutting internal threads into a drilled hole by using a tap is known as tapping. For tapping, the following procedure is adopted:

1. First of all, a hole is drilled to a diameter smaller than the outside diameter of the threading the tap i.e., equal to the core diameter. The diameter of the hole to be drilled is called tapping size. Mathematically,

$$\text{Tapping size} = \text{Outside diameter} - 2 \times \text{Depth of thread}$$

$$\text{Where, Depth of thread} = 0.64 \times \text{Pitch of thread}$$

2. After drilling the tapping hole, the taper tap is fixed in the tap wrench and screwed in the hole. Before commencing to screw it round for cutting the thread, the tap position must be adjusted until it stands square with the tap surface of the work and it must be maintained square.

3. For all materials except cast iron a little whale oil on the tap is applied to lubricate its action and improve the finish of the threads.

4. When the taper tap is felt to have started its work and its squareness has been checked, the cutting of threads proceeds. It should be kept in mind that the tap is not turned continuously, but at every half-turn it should be reversed slightly to clear the threads.

5. When the hole is straight through, the reduction of resistance indicates the taper tap cutting a full thread and it may be removed from the hole which may be finished with the second tap.

6. When a blind hole is tapped, the tap should be withdrawn from time and the metal cleared from bottom of the hole.

### DIES -

A tool used for cutting external threads on bars or tubes is called a die. It consists of a nut having portions of its thread circumference cut away and shaped to provide cutting edges to the

remaining portions of the threads. After hardening and sharpening of the cutting edges, this is screwed on to the bar upon which the thread is to be cut. In order to hold and manipulate the die it is carried in the centre of a pair of operating handles called stocks.

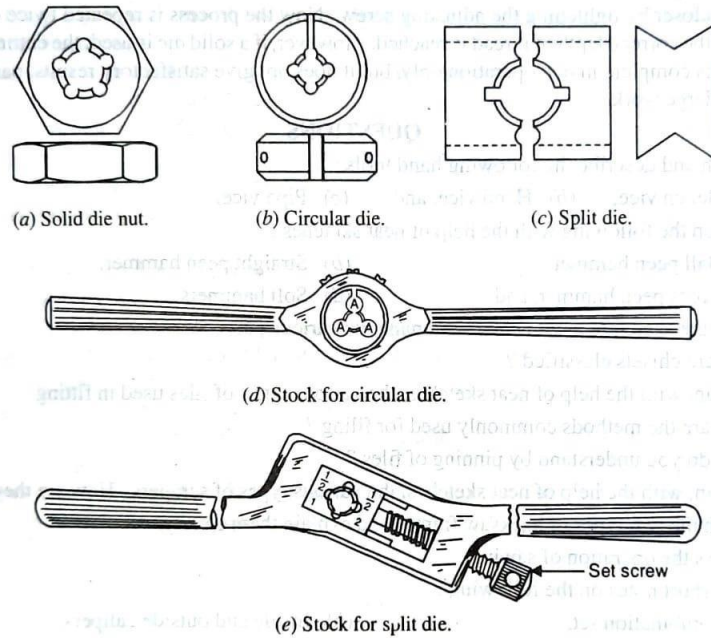

Fig. 1.35 various Dies



## JOB NO. 01

<b>DATE:</b>	<b>SECTION:</b>
<b>NAME:</b>	<b>COMPLETE:</b>
<b>REG. NO:</b>	<b>MARKS:</b>
<b>BRANCH:</b>	<b>Sign. Of Sr. Lect / Lecturer</b>

### AIM OF THE EXPERIMENT:

Cutting and Fitting practice on a square of 50mm x 50mm x 8mm MS FLAT

### OBJECTIVE OF THE EXPERIMENT:

1. Mark the material with a scribe as per drawing.
2. Punch the material with a Dot-punch on the marked line.
3. Use hacksaw to cut the required material after marking.
4. Fill the two adjacent sides of the material to Right angle.
5. File the material to obtain the required dimension.

### TOOLS AND EQUIPMENT REQUIRED

SERIAL NO	NAME OF EQUIPMENT	SPECIFICATION / TYPE	QUANTITY
01	Bench vice	125 mm	
02	Try square	100 mm	
03	Hacksaw frame with blade	Adjustable	
04	Scriber	150mm	
05	Steel rule	300 mm	
06	Dot punch	100mm	
07	Ball Peen Hammer	700 gm	
08	Vernier Height gauge	300 mm	
09	Surface Plate	500x500x25 mm	
10	Angle plate	150x150x100x25 mm	
11	Triangular File	150 mm	
12	Flat file Bastard	300 mm	
13	Half Round File	150 mm	

### Raw Material Required:

1. M.S.FLAT : As per specified given job diagram.

**JOB FIGURE:**

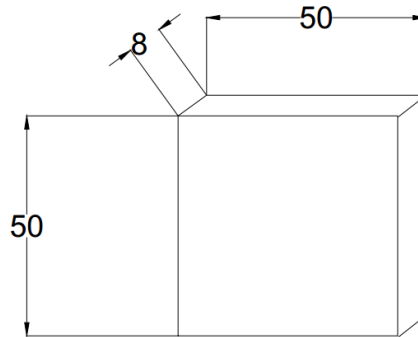

**PROCEDURE:**

1. Study the job figure and choose the raw material according to the dimensions.
2. Mark the raw material and cut accordingly..
3. File adjacent sides for right angle using TRY SQUARE.

**OBSERVATION TABLE:**

PARAMETERS	DESIRED DIMENSION IN mm	ACTUAL DIMENSION IN mm	DEVIATION FROM ALLOWABLE TOLERANCE	REASONS FOR DEVIATION
Length of the Job				
Breadth of the Job				

**CONCLUSION:**

Explain the reasons for deviation from the given specifications of the finished job.  
Suggest methods for improvement of quality of the job.

**ASSIGNMENT QUESTIONS**

1. Name different types of files used for this job?
2. Describe the method of marking?
3. Name tools to be used for marking and cutting operations?
4. What are the measuring tools to be used to prepare the job?
5. Draw the sketch of the given job?

**WRITING SPACE FOR ASSIGNMENT**

## JOB NO.02

<b>DATE:</b>	<b>SECTION:</b>
<b>NAME:</b>	<b>COMPLETE:</b>
<b>REG. NO:</b>	<b>MARKS:</b>
<b>BRANCH:</b>	<b>Sign. Of Sr. Lect / Lecturer</b>

**AIM OF THE EXPERIMENT:** Angular cutting Practice of 45 Degree

**OBJECTIVE OF THE EXPERIMENT:**

2. Mark the material with a scribe as per drawing.
4. Punch the material with a Dot-punch on the marked line.
5. Use hacksaw to cut the required material after marking.
6. Fill the two adjacent sides of the material to Right angle.
7. File the material to obtain the required dimension.

**TOOLS AND EQUIPMENT REQUIRED**

SERIAL NO	NAME OF EQUIPMENT	SPECIFICATION / TYPE	QUANTITY
01	Bench vice	125 mm	
02	Try square	100 mm	
03	Hacksaw frame with blade	Adjustable	
04	Scriber	150mm	
05	Steel rule	300 mm	
06	Dot punch	100mm	
07	Ball Peen Hammer	700 gm	
08	Vernier Height gauge	300 mm	
09	Surface Plate	500x500x25 mm	
10	Angle plate	150x150x100x25 mm	
11	Triangular File	150 mm	
12	Flat file Bastard	300 mm	
13	Half Round File	150 mm	

**Raw Material Required:**

M.S.FLAT : As per specified given job diagram.

**JOB FIGURE:**

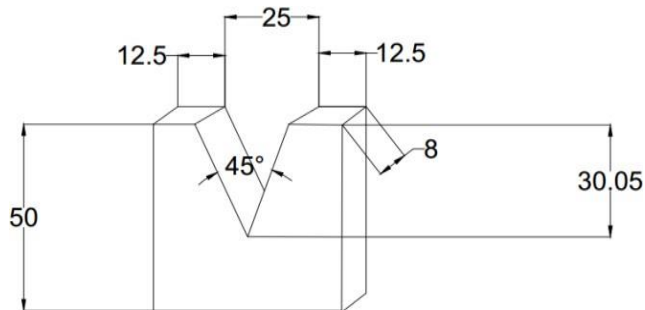

**PROCEDURE:**

2. Study the job figure and choose the raw material according to the dimensions.
3. Mark the raw material and cut accordingly.
4. File adjacent sides for right angle using TRY SQUARE.
4. Mark one surface after using Marking Media.
5. Mark one side of the job using Surface Plate, Angle Plate and Vernier Height Gauge.
6. Make punch on the marked lines.
7. Cut out the undesired part and use file to get the required dimensional accuracy.

**OBSERVATION TABLE:**

PARAMETERS	DESIRED DIMENSION IN mm	ACTUAL DIMENSION IN mm	DEVIATION FROM ALLOWABLE TOLERANCE	REASONS FOR DEVIATION
Length of the Job				
Angle of the Job				

**CONCLUSION:**

Explain the reasons for deviation from the given specifications of the finished job. Suggest methods for improvement of quality of the job.

**ASSIGNMENT QUESTIONS**

1. What is the least count of vernier height gauge?
2. Describe the methods of marking in this job?
3. Name the different parts of a ball peen hammer?
4. What is the angle of a dot punch?
5. Name the different parts of a file?

**WRITTING SPACE FOR ASSIGNMENT**

### JOB NO.03

<b>DATE:</b>	<b>SECTION:</b>
<b>NAME:</b>	<b>COMPLETE:</b>
<b>REG. NO:</b>	<b>MARKS:</b>
<b>BRANCH:</b>	<b>Sign. Of Sr. Lect / Lecturer</b>

#### AIM OF THE EXPERIMENT:

Preparation of stud (to cut External Threads) with the help of Dies

#### OBJECTIVE OF THE EXPERIMENT:

1. Mark the material with scribe as per drawing.
2. Make the external thread with the help of a die.
3. Chamfer the sharp edges of the job

#### TOOLS AND EQUIPMENT REQUIRED

SERIAL NO	NAME OF EQUIPMENT	SPECIFICATION / TYPE	QUANTITY
01	Bench vice	125 mm	
02	Try square	100 mm	
03	Hacksaw frame	Adjustable	
04	Outside slide calliper	150 mm	
05	Steel rule	300 mm	
06	Die	M10	
07	Die Stock		
08	Dot punch		
09	Ball Peen Hammer	700 gm	

#### Raw Material Required:

M.S.ROD : As per specified given job diagram.

## JOB FIGURE:

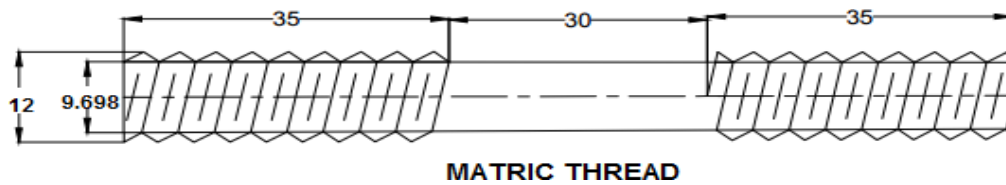

## PROCEDURE:

1. Rub emery cloth to remove rust and loose scale.
2. File the required length.
3. Square the middle portion with a file.
4. Make external threads on both the ends with the help of a die according to the suitable Matric Thread Die.
5. Chamfer both the ends.

## OBSERVATION TABLE:

PARAMETERS	DESIRED DIMENSION IN mm	ACTUAL DIMENSION IN mm	DEVIATION FROM ALLOWABLE TOLERANCE	REASONS FOR DEVIATION
Length of the stud				
Length of the thread				
Diameter of the stud				

## CONCLUSION:

Explain the reasons for deviation from the given specifications of the finished job. Suggest methods for improvement of quality of the job.

## ASSIGNMENT QUESTIONS

1. How External threads are cut manually?
2. What tools will one use for external thread?
3. Describe different parts of a thread?
4. What do you mean by Chamfer?
5. Draw of the sketch diagram of given job?



**WRITTING SPACE FOR ASSIGNMENT**

-

## JOB NO. 04

<b>DATE:</b>	<b>SECTION:</b>
<b>NAME:</b>	<b>COMPLETE:</b>
<b>REG. NO:</b>	<b>MARKS:</b>
<b>BRANCH:</b>	<b>Sign. Of Sr. Lect / Lecturer</b>

**AIM OF THE EXPERIMENT:** H-fitting in the Mild Steel (MS) square

**OBJECTIVE OF THE EXPERIMENT:**

1. Use Hacksaw to cut the required material after marking.
2. File the material to get required dimensions.

**TOOLS AND EQUIPMENT REQUIRED:**

SERIAL NO	NAME OF EQUIPMENT	SPECIFICATION / TYPE	QUANTITY
01	Bench vice	125 mm	
02	Try Square	100 mm	
03	Steel Rule	300 mm	
04	File Flat Bastard	300 mm	
05	File triangular	150 mm	
06	Hacksaw Frame with blade	300 mm	
07	Surface Plate	500×500×25 mm	
08	Scriber	150 mm	
09	Dot Punch	100 mm	
10	Ball Peen Hammer	200 gm	
11	Angle Plate	150x150x100x25 mm	

**RAWMATERIAL REQUIRED:**

M.S. FLAT: 65×50×5 mm

## JOB FIGURE:

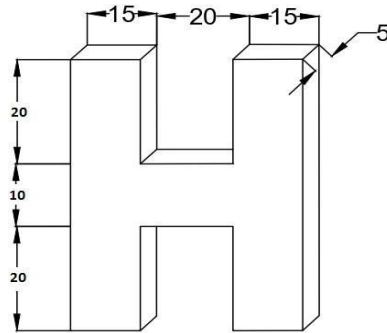

## PROCEDURE:

1. Study the job figure and select the required raw material.
2. Mark it with help of Scriber, Try Square, and keep cutting Allowances.
3. Hold the job on the Bench vice and cut from the markings using a hacksaw.
4. File the sides to make it all sides of the job right angle by using Try square.
5. Make chulking in one side of job and marking using a dot punch and hammer.
6. Place the job on the surface plate and mark using height gauge.
7. Mark the part to be removed and start cutting.
8. After cutting remove the undesired part and file the surface keeping tolerance in mind.
9. The H fitting is finally made.

## OBSERVATION TABLE:

Tolerance:  $\pm 0.25\text{mm}$

PARAMETERS	DESIRED DIMENSIONS IN mm	ACTUAL DIMENSIONS IN mm	DEVIATIONS IF ANY
Height of the Job			
Width of the Job			
Height of the flange			

## CONCLUSION:

Explain the reasons for deviation from the given specifications of the finished job. Suggest methods for improvement of quality of the job.

## ASSIGNMENT QUESTIONS

1. Name the different types of files?
2. Describe methods of marking by using vernier height gauge, angle plate and surface plate?
3. Draw the sketch of the given job?

**WRITTING SPACE FOR ASSIGNMENT**

<b>DATE:</b> <b>NAME:</b> <b>REG. NO:</b> <b>BRANCH:</b>	<b>SECTION:</b> <b>COMPLETE:</b> <b>MARKS:</b>  <b>Sign. Of Sr. Lect / Lecturer</b>
---	---

## JOB NO. 05

**AIM OF THE EXPERIMENT:** Prepare a triangular Male and Female joint

**OBJECTIVE OF THE EXPERIMENT:**

1. Use hacksaw to cut the required material after marking.
2. File the material to the required dimension and angle.
3. Bring together the Male and Female part and look for any light gap if present.
4. File the rough surfaces to give it a shiny finish.

**TOOLS AND EQUIPMENT REQUIRED**

SERIAL NO	NAME OF EQUIPMENT	SPECIFICATION / TYPE	QUANTITY
01	Bench vice		
02	Steel rule		
03	Try square		
04	Ball peen hammer		
05	Scriber		
06	Hack saw with blade		
07	Dot punch and Centre punch		
08	Surface plate		
09	Venire height gauge		
10	Rough and smooth flat files		
11	Flat chisel and triangular file		

**Rawmaterial Required:**

M.S. FLAT: 50×50×8 mm (2 NUMBERS)

**JOB FIGURE:**

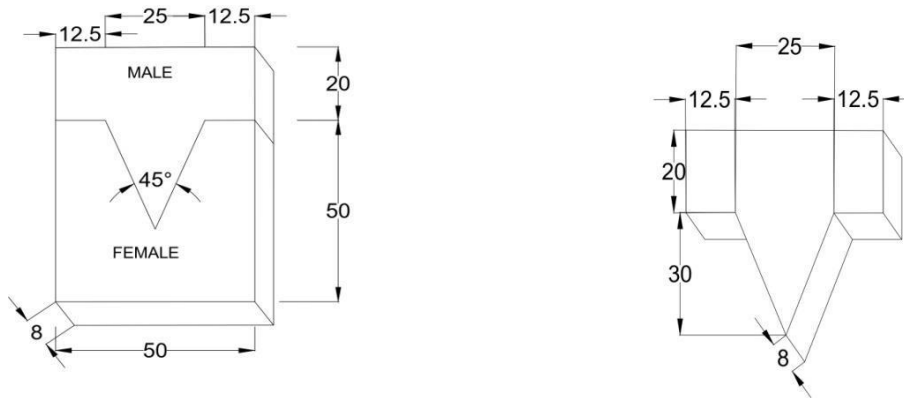

**PROCEDURE:**

1. Study the job figure and choose the raw material according to the dimensions.
2. Mark the raw material and cut accordingly for the Male and Female part.
3. File adjacent sides for right angle using TRY SQUARE.
4. Mark one surface of both the joints.

**FOR MALE:**

1. Mark one side of the job using Surface Plate, Angle Plate and Vernier Height Gauge.
2. Make punch on the marked lines.
3. Cut out the undesired part and use file to get the required dimensional accuracy.

**FOR FEMALE:**

1. Follow the same procedure for female part.
2. Fit the triangular male and female parts.

**OBSERVATION TABLE:**

PARAMETERS	DESIRED DIMENSIONS IN mm	ACTUAL DIMENSIONS IN mm	DEVIATIONS IF ANY IN mm
Length of the Job			
Angle of the Job			

**CONCLUSION:**

Explain the reasons for deviation from the given specifications of the finished job. Suggest methods for improvement of quality of the job.

**ASSIGNMENT QUESTIONS**

1. What are the measuring tools used to prepare the job?
2. What is the least count of vernier calliper you have used ?
3. What is the material of hacksaw blade?

**WRITTING SPACE FOR ASSIGNMENT**

# SHEET METAL

## INTRODUCTION

The sheet metal shop is very important for every engineering concern. It deals with the working of metal sheets. It requires a thorough knowledge of projective geometry particularly the development of surfaces, because the laying out of pattern and cutting of metal sheets to correct sizes and shapes entirely depends upon the knowledge of the workman. The various operations performed in a sheet metal shop are cutting, shearing, bending etc. In this chapter, we shall discuss the sheet metal tools and the various processes.

## SAFETY PRACTICES

1. Use hand leather gloves while handling heavy sheets.
2. Avoid feeling the cut portion by hand while cutting with snips.
3. Do not let sheet metal slip through your hands. Most cuts from sheet metal result from allowing it to slide through the hands.

## BASIC CONCEPT OF DEVELOPMENT OF A SURFACE

Consider that a Cylinder is wrapped round its curved surface by a piece of paper. If this wrapper is opened out and spread over a plane surface the rectangle a b c d formed by this spread piece of paper is the Development of the surface. The rectangle a b c d represents the whole curved surface of the solid in its true full sized dimensions such that if this piece is refolded, with its ends abutting against each other, it will form the same cylindrical shape again and will measure exactly equal to the solid in all dimensions. If due allowance is provided at the edges of this rectangle to form the seam it can very well be used as a Template for cutting metal sheets to prepare hollow cylinders of the same dimensions as those of the given cylinder. It is very important, therefore that all the lines on the development of a surface must represent the true length of the corresponding line on that surface.

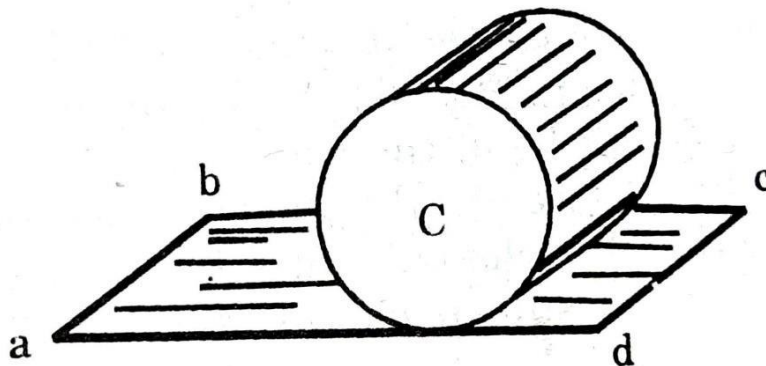

Fig. 2.1 Surface Development

## PRACTICAL EXERCISES OF PATTERN LAYOUT AND JOB MAKING

### Exercise 1.

To Prepare a Right Angle Elbow of 25 mm diameter.

The elbow consists of two formed parts A and B of cylindrical shapes joined along the seam P-6 as shown in the front elevation



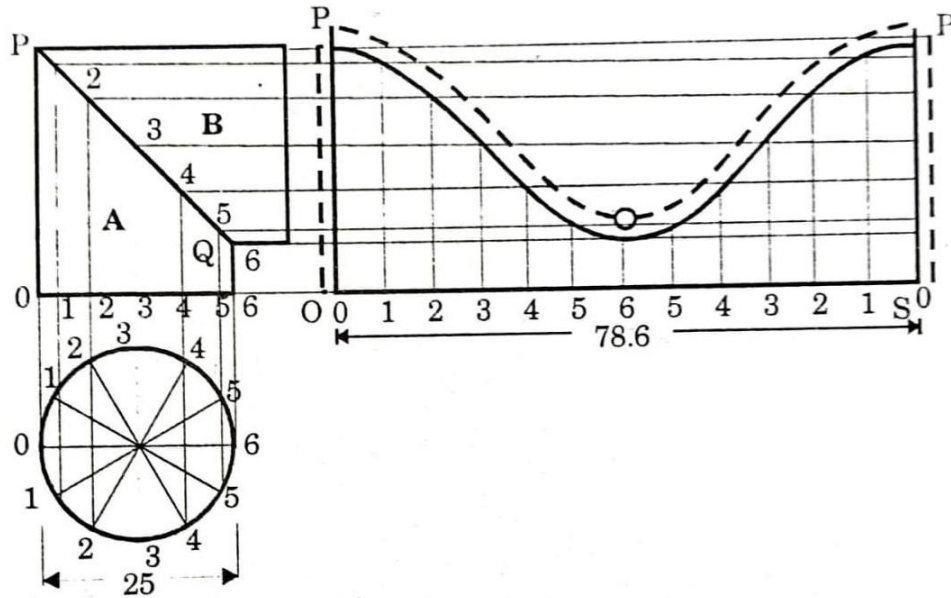

Layout of a right angle elbow.

Fig. 2.2

The Pattern Layout or Development of one of the two pieces (i.e. of A) is given. The projected part shown by dotted line is the required allowance for edge preparation. Development of the other piece will be similar, hence omitted.

## METALS USED IN SHEET METAL WORK

The following metals are generally used in sheet metal work:

1. Black iron sheet. It has a bluish-black appearance and is often referred to as uncoated sheet. Since it is uncoated, therefore, it corrodes rapidly. The use of this metal is limited to articles that are to be painted or enameled such as stove pipes, tanks and pans.
2. Galvanised iron. It is soft steel coated with molten zinc. The zinc coating resists rust, improves the appearance of the metal, and permits it to be soldered with greater ease. The galvanized iron sheet is used extensively in fabricated products such as pans, buckets, furnaces, heating ducts, cabinets, gutters and in many other articles.
3. Copper. It is a reddish coloured metal and is extremely malleable and ductile. It is used extensively in the electrical field. Since it does not deteriorate rapidly when exposed to the atmosphere, therefore, this metal is employed frequently in the building trades for water pipe, roofing, gutters and other parts of buildings.
4. Aluminum. It is a silvery white coloured metal and has many qualities like high ratio of strength to weight, corrosion resistant qualities and ease in fabrication. Now-a-days it is used in the manufacture of number of products such as household appliances, refrigerator trays, lighting fixtures, windows, duct work, in construction of airplanes, in the building trades, and in many electrical and transportation industries.
5. Stainless steel. It is an alloy steel possessing the ability to resist corrosion without any surface coating. One important type of stainless steel contains 18 percent chromium and 8 percent nickel. This steel is commonly known as 18/8 steel. It is widely used in building stream

lined trains, food handling equipment's, kitchenware's and in many other applications which require great strength and resistant to corrosion

## SHEET METAL TOOLS

The tools commonly used in sheet metal work are as follows:

**Rules.** The rules are available in a variety of lengths and types, each of which is designed for measuring and laying out different work. The following rules are generally used in sheet metal shop.

**1. Steel rule, folding rule and steel tape.** The steel rule (30 cm long) is particularly useful in measuring and laying out small work. The folding rule (2 meters long) and the steel tape respectively are very helpful in measuring and laying out large work. In order to measure accurate distance, the rule should be placed on its edge so that the graduations are in actual contact with the metal.



Steel rule

folding rule

steel tape

Fig. 2.3 Measurement Tools

**2. Steel square.** It is a L-shaped piece of hardened steel with graduation marks on the edges for measuring. The narrow arm of the square is called the tongue and the wide part is known as the body



Steel square

Swinging blade protractor

Fig. 2.4

**3. Swinging blade protractor** – it is used in sheet metal work are made of steel. These are used for marking or measuring angles.

**4. Straight edge.** It is a flat bar of steel with a bevelled edge. This bar comes in a variety of lengths ranging from 1 metre to 3 metre. It is useful for drawing long lines.

5. **Scratch awls or scribes.** They are used to scribe or mark lines on a metal surface for a variety of purposes in laying out patterns. The following are the three common types of scratch awls.

(a) **Ring scratch awl:** It is a solid steel rod about 5 mm in diameter and 150 mm to 200 mm long. It has a sharp tapered point at one end and a ring at the other end.

(b) **Socket scratch awl:** It has a steel blade about 150 mm and provided with a replaceable wooden handle.

(c) **Shank type scratch awl:** For general purposes, this type of scratch awl is preferred by most sheet metal workers because the steel blade passes through the handle which reinforces the top.



Ring scratch awl

Socket scratch awl

Shank type scratch awl

Fig. 2.5

## SHEET METAL HAMMER

Light weight hammers and mallets are used in sheet metal work. Ball peen hammer has a cylindrical, slightly curved face and a ball head. It is a general-purpose hammer, used mostly for riveting in sheet metal work. Cross peen hammer has a tapered peen end and is perpendicular to the handle. Mallet is used for bending and folding work. Bullet head or bullet face hammer are used to make the job made of light sheets hollow and riveting hammer is used for reveal joint jobs in sheet metal work.

**Hammers:** The hammers, in sheet metal work, are used for forming, raising, stretching or throwing off processes. There are many types of hammers, but the most commonly used hammers, in sheet-metal work, are as follows:

(a) **Ball peen hammer.** The ball peen hammer has a round, slightly curved face and a round head. It is a general purpose hammer.

(b) **Riveting hammer.** The riveting hammer has a square, slightly curved face with bevelled edges to prevent the head of the hammer from marking the metal. The peen side is double tapered and has a slightly rounded end. It is used for spreading rivets and for hammering a rivet set.

(c) **Setting hammer.** The setting hammer has a square, flat face and a tapered peen with bevelled end. The flat face is used for flattening seams without damage to the metal while peen end is used for peening operation.

(d) **Hollowing or blocking hammer.** The hollowing or blocking hammer has a dome face without any sharp corners. It is used for hollowing discs into bowl shapes.

(e) **Raising hammer.** The raising hammer, has an oblong flat face with corners slightly rounded off. It is used in raising circular discs and many other raising and bumping operations.

- (f) **Planishing hammer.** The planishing hammer has a round face. It is used on domed circular work.
- (g) **Collect hammer.** The collect hammer has an oblong shaped faces. It is used on cylinders and in curved collects.
- (h) **Tray hammer.** The tray hammer has oval shaped faces. It is used to sink the bottom when shaping a tray.

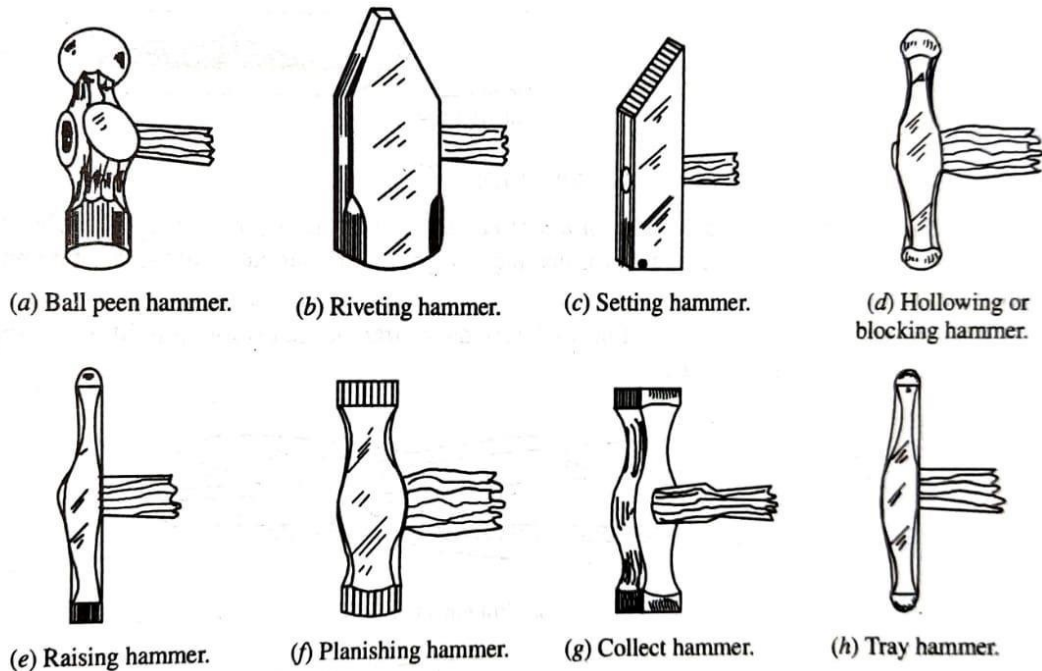

Fig. 2.6 various types of Hammers

- (i) **Mallets.** The mallets may be made from hide, fibre or wood. The best size of mallet is 5 cm diameter. These may be obtained in various shapes to suit special work.

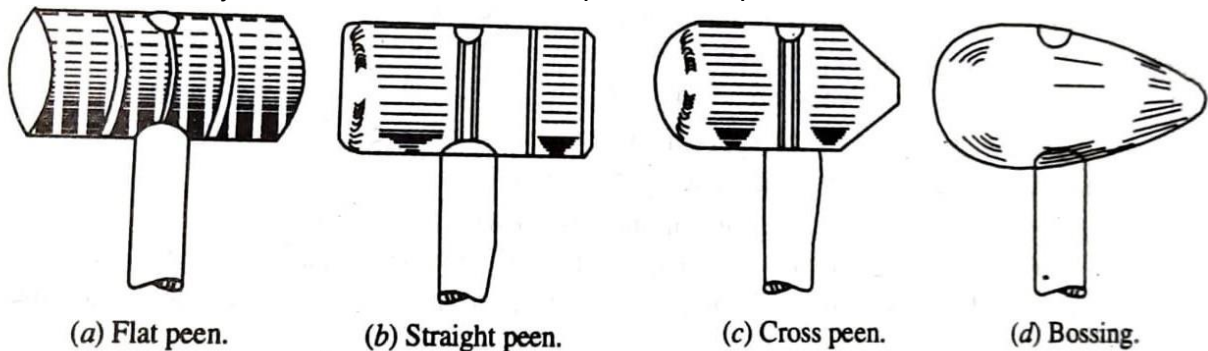

Fig. 2.7 Various types of Mallets

### CHISEL:

The cold chisels are used to cut or shear metal. It is made from a piece of high carbon or alloy steel of hexagonal or octagonal in shape. There are many different types of chisels, but the flat chisel is mostly used for cutting sheet metal, rivets, bolts and in chipping operations. The flat chisel has a tapered end with a sharp cutting edge which is properly hardened and tempered. The edge is bevelled to an angle of  $40^\circ$  to  $45^\circ$  for cutting sheet metal.

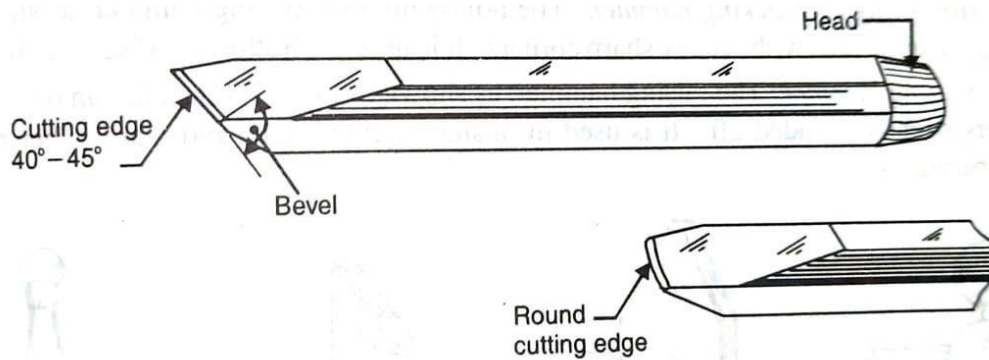

Fig. 2.8 Chisel

**SNIPS:**

The snips are somewhat similar to a pair of scissors but are considerably heavier. There are several types of snips available for making straight or circular cuts, but the most common are the straight snips and the curved snips.

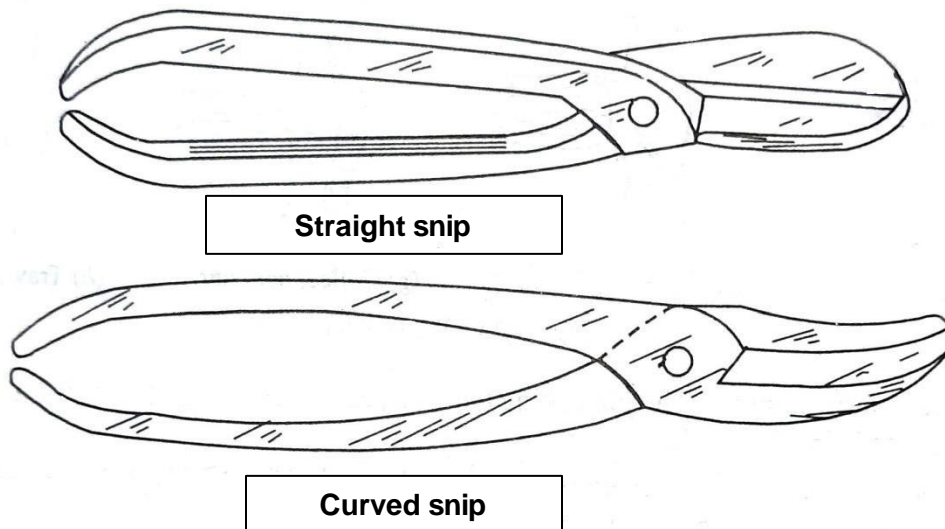

Fig. 2.9

**DIVIDER:**

Divider is used in sheet metal jobs for circle marking. With the divider we can also do marking the parts of a job.

**TRAMEL:**

The trammel points (sometimes called a beam compass), as consists of two straight, removable legs tapered to needle points and attached to separate heads or holders. These heads or holders slide on wood or steel bars or beams and are held in place by thumb screws. A special clamp for a pencil can be attached to one of the points. The trammel points are used to draw large arcs and circles that are beyond the limit of dividers.

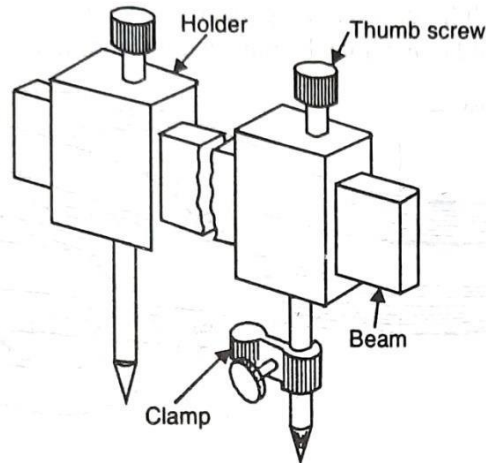

Fig. 2.10 Trammel

**PLIERS:**

Pliers are used for holding or cutting and bending small jobs or wires etc. The various types of pliers commonly used are as follows:

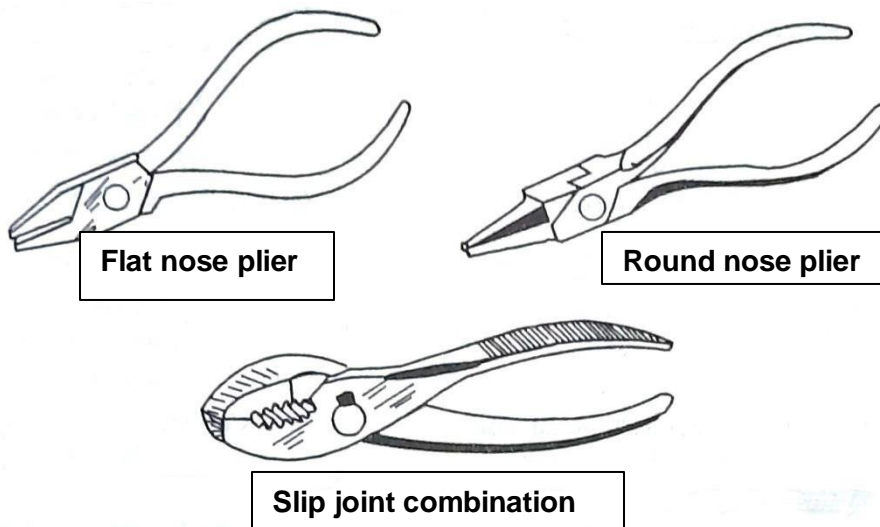

Fig. 2.11 Different Pliers

**SHEARS:**

This is also used like snip for cutting metal sheets but it is used to cut thicker sheets as compared to snip. This is of two types such as Stock shear and Block shear.

**SHEET METAL BENCH TOOL:**

- a. Vice
- b. Stakes
- c. Grooved Bench Plate

**VICE:**

Vice is used in sheet metal works for holding sheets or jobs. Normally, parallel jaw vice is used in sheet metal works.

**STAKE:**

Stake is the sheet-metal worker's anvil, used for bending, seaming or forming, using the hammers and mallets. They actually work as supporting tools as well as forming tools. They help in bending operation. They are of different shapes and sizes to suit the requirements of the work.

The double seaming stake is used to make double seam. The beak horn stake is used for riveting, forming round and square surfaces, bending straight edges and marking corners. The bevel edges square stake is used to form corners and edges. The hatchet stake is used to make straight sharp bend and for folding and bending edges. Small tools and pipes may be formed on the needle case stake and cone-shaped articles may be formed on blow-horn stake. The hollow mandrel stake is used for riveting, seaming and forming.

**GROOVERS AND RIVET SETS:**

Hand Groovers are used to groove and flatten a seam. This available in many shapes. Rivet set is a hardened steel tool with a hollow in one end. It is used to shape the end of a rivet into a round or smooth head.

**BENCH PLATE:**

The bench plate is a special type of plate made of carbon steel. Different types of holes, round, square, in different shapes and sizes are made in this plate. Different types of stakes are fixed in these holes and used.

## JOB NO. 06

<b>DATE:</b>	<b>SECTION:</b>
<b>NAME:</b>	<b>COMPLETE:</b>
<b>REG. NO:</b>	<b>MARKS:</b>
<b>BRANCH:</b>	<b>Sign. Of Sr. Lect / Lecturer</b>

### AIM OF THE EXPERIMENT:

To make sheet metal joints.

### OBJECTIVES OF THE EXPERIMENT :

- Use snip to cut the sheet
- Make a seam on the edge
- Bend the sheet metal on a taper bar

### SET UP OF THE JOB:

#### Equipment Required :

SERIAL NO	NAME OF EQUIPMENT	SPECIFICATION / TYPE	QUANTITY
01	Steel Rule		
02	Straight Edge		
03	Hammer		
04	Try Square		
05	Snip		
06	Scriber		
07	Mallet		
08	Hatchet stake		
09	Bench Plate		
10	Standard wire Gauge		

Raw Material Required :G.I. sheet .

### JOB FIGURE :



Lap Seam



Grooved (locked)  
Seam



Single Seam



**PROCEDURE:****For Lap Seam –**

1. Cut the G.I sheet according to the given specification
2. Place one sheet upon another keeping half of the breadth outside.
3. Now we can make joint by soldering or riveting.

**For grooved Seam –**

1. Cut the G.I sheet according to the given specification in two pieces
2. A line is marked one half the width of the seam from the edge of the pieces and then draw another line equal to the width of the grooved seam required.
3. Now bend two edges and hook them together
4. Then placed it on a hollow mandrel stake or a stake having a suitable curvature
5. Then flatten the seam slightly with a mallet.
6. The hand groover with a correct size is fitted over on one end of the seam and struck with a mallet.
7. This process is repeated on the other end of the seam to prevent the edges from coming apart
8. The entire seam is grooved by striking the groover while moving it over the seam.
9. The operation is completed by flattening the seam with a mallet.

**For single Seam –**

1. First of all, draw a line parallel to one edge of the body stretchout at a distance equal to the width of seam
2. Draw two lines parallel to the edges of the bottom stretchout
3. The plus and minus dimensions of 1 mm are used to prevent the folded edge of the bottom from interfering with the folded edge of the body
4. Now form the flange on the body and on the bottom piece by folding the metal with a mallet over a suitable stake or wooden block
5. Insert the other part of the job in the bottom piece and place the assembled parts on a flat stake.
6. Bend the edge of bottom gradually over the edge of the body with a setting hammer.

**CONCLUSION :**

Explain the reasons for deviation between given specification and finished job. Suggest suitable methods for improvement of quality of the job.

**ASSIGNMENT QUESTIONS**

1. What is a seam ?
2. State different types of seam ?
3. State the use of groove ?
4. Draw the sketch diagram of the given job.

## WRITING SPACE FOR ASSIGNMENT

## JOB NO. 07

<b>DATE:</b>	<b>SECTION:</b>
<b>NAME:</b>	<b>COMPLETE:</b>
<b>REG. NO:</b>	<b>MARKS:</b>
<b>BRANCH:</b>	<b>Sign. Of Sr. Lect / Lecturer</b>

### AIM OF THE EXPERIMENT:

To Prepare and Make a Taper Tray

### OBJECTIVES OF THE EXPERIMENT :

- Use snips to cut the sheet for the development of a taper square tray
- Make Double Hem on the edges.
- Bend the sheet on hatchet stake.
- Soft solder lap joint.

### SET UP OF THE JOB:

#### Equipment Required :

SERIAL NO	NAME OF EQUIPMENT	SPECIFICATION / TYPE	QUANTITY
01	Steel Rule		
02	Folding Rule		
03	Straight Edge		
04	Try Square		
05	Scriber		
06	Divider		
07	Punch		
08	Chisel		
09	B.P Hammer		
10	Snip		
11	Soldering Iron		
12	Mallet		

#### Raw Material Required :

- G.I. sheet : As Per Specified Given Job Diagram.
- Soft solder: As Per Specified Given.

**JOB FIGURE :**

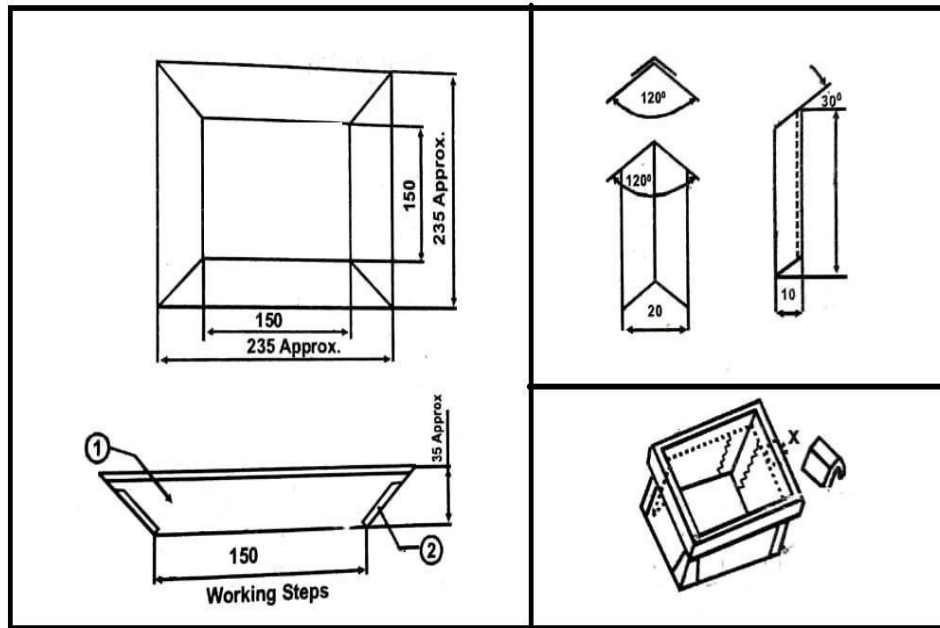

**PROCEDURE:**

- Check the size of the sheet as per the sketch using a steel Rule.
- Level the sheet on a leveling plate by a mallet.
- Mark out the development of the sheet by the parallel line method as per dimension."
- Cut away waste material
- Cut the four corner flaps and bend to 120°.
- Bend the 4 edges to double Hem on the outside
- Clamp the work on the scribed line.
- Bend the all the 4 sides as per drawing.
- Check the size and shape (Make corrections, if necessary).
- Solder the four flaps on the outside, each on one corner.
- Painting the tray with red oxide by Brush Paint. Give a finished coat either by spray painting or hand painting.

**OBSERVATION :**

	DESIRED DIMENSION IN mm	ACTUAL DIMENSION IN mm	DEVIATION IF,ANY
Length of the tray			
Width of the tray			
Depth of the tray			
Angle of inclination			

**CONCLUSION :**

Explain the reasons for deviation between given specification and finished job. Suggest suitable methods for improvement of quality of the job.

**ASSIGNMENT QUESTIONS**

1. What is a seam ?
2. State different types of seams ?
3. State the use of a Groove ?
4. State the process of Soldering .
5. Explain, why the tip of a soldering iron is made of copper ?
6. Draw the sketch diagram as per given job ?

**WRITING SPACE FOR ASSIGNMENT**

## JOB NO.08

<b>DATE:</b>	<b>SECTION:</b>
<b>NAME:</b>	<b>COMPLETE:</b>
<b>REG. NO:</b>	<b>MARKS:</b>
<b>BRANCH:</b>	<b>Sign. Of Sr. Lect / Lecturer</b>

### AIM OF THE EXPERIMENT:

To Prepare a lap riveting joint.

### OBJECTIVES OF THE EXPERIMENT :

- Special Tinner rivets are to be used
- Cut the sheet with the help of hand shear

### SET UP OF THE JOB:

#### Equipment Required :

SERIAL NO	NAME OF EQUIPMENT	SPECIFICATION / TYPE	QUANTITY
01	Rivet Sets		
02	Trammel		
03	Standard Wire Gauge		
04	Steel rule		
05	Hand shear		
06	Steel Square		
07	Scriber		
08	Riveting Hammer		
09	Punch		

#### Raw Material Required :

- G.I. sheet : As Per Specified Given Job Diagram.
- Soft solder: As Per Specified Given.

**JOB FIGURE :**

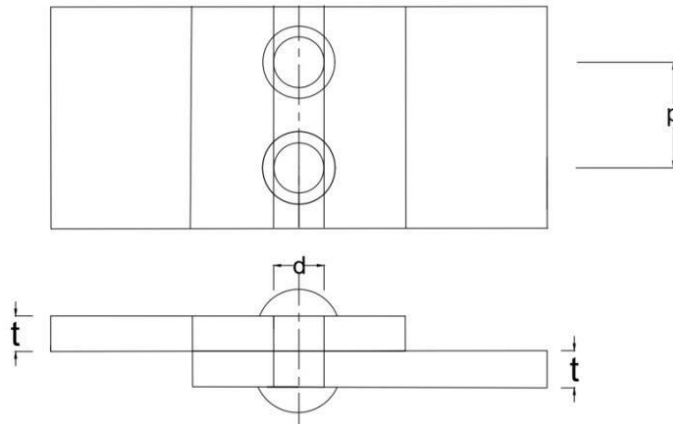

**PROCEDURE:**

- a. Cut the desired sheet according to the specification given in the drawing.
- b. Place one sheet on another according to the drawing
- c. drill or punch the holes of correct size. Insert the rivet in the hole and place the head on some metal bar or stake.
- d. Place the deep hole of the rivet set over the rivet and strike the rivet set with few sharp blows
- e. This draws the metal and rivet together.
- f. Remove the rivet set and flatten the end of the rivet with the face of a riveting hammer or ball peen hammer.
- g. It should be noted that each blow of hammer should hit the rivet shank squarely.
- h. Place the cup shaped opening of the rivet set over the flattened rivet end, and strike the rivet set until the head is shaped properly

**OBSERVATION :**

	DESIRED DIMENSION IN mm	ACTUAL DIMENSION IN mm	DEVIATION IF,ANY
Pitch of the Rivets			
Dia of the Rivets			
Assume any suitable data			

**CONCLUSION :**

Explain the reasons for deviation between given specification and finished job. Suggest suitable methods for improvement of quality of the job.

**ASSIGNMENT QUESTIONS**

1. What is the difference between the permanent joint and temporary joint?
2. What is called heading process?
3. What is called Drawing process?
4. Draw the figure of above Job.

**WRITING SPACE FOR ASSIGNMENT**



# WELDING SHOP

## INTRODUCTION

Welding is a process of joining similar or dissimilar metals by application of heat with or without application of pressure and addition of filler material. Now-a-days many processes of welding have been developed and probably there is no industry which is not using welding process in the fabrication of its products in some form or the other. This is the most rapid and easiest way of fabrication and assembly of metal parts. The research carried out in this field has given various ways and methods to weld practically all metals. Means have also been found out to weld dissimilar metals. One beauty of welding in comparison to other processes of joining metals is that by this process we can have more than 100% strength of joint and it is very easy process. We shall be dealing with the various processes of welding in use these days, the equipment used for each process and the ways of preparation of joint and the Various operations necessary.

## SAFETY PRECAUTIONS IN WELDING

Welding is associated with several types hazards to health and safety. The workshop / welding shop should be well ventilated to reduce fumes and hazardous gases generated during welding. The following factors must be considered:

1. Optical radiation: - The welding process produces a large quantity of visible light, ultraviolet and infrared. Exposure to the radiation from an arc causes burns to the skin, and damage to the eyes. For this reason, welders need to wear clothing to protect their bodies and arms, regardless of the weather conditions. They also need efficient eye protection, which is usually supplied in the form of a protective shield. The precise choice of the shade of glass filter in these shields depends on the type of welding operation, since they vary in their light output.

2. Fumes: - Welding vaporizes metals, and other contaminated materials, traced on the surface. This gives rise to fume, which is condensed to fine precipitates. The fume is mostly oxides of the metals, including any alloying elements, but it also contains gases produced in the arc, such as ozone oxides of nitrogen, and decomposed products from any paint or coating which was on the metal surface. The nature and quantity of this fume depends critically upon the welding process, the materials and the welding parameters. Some are harmful to health; for instance stainless steel fume contains chromium, and welding galvanised steel produces zinc fume. Monitoring instruments should be used to detect harmful atmospheres. Where it is impossible to provide adequate ventilation, air-supplied respirators or hose masks approved for this purpose must be used.

3. Burns and Mechanical Hazards:-Welders need good quality clothes, safety boots or shoes and good quality cap and overalls. A leather apron may also be needed. Welding produces quantities of molten droplets of metal which are Scattered in all directions. It is essential that the welder wears clothing which will not burn or melt, and which is stout enough to provide adequate protection. To prevent injury to personnel, extreme caution should be exercised when

using any types of welding equipment. Injury can result from fire, explosions, electric shock, or harmful gases.

## **GENERAL SAFETY MEASURES**

1. Do not weld in a building with wooden floors, unless the floors are protected from hot metal by means of fire resistant fabric, sand, or other fireproof material. Be sure that hot sparks or hot metal will not fall on the operator or on any welding equipment components.
2. Remove all flammable material, such as cotton, oil, gasoline, etc., from the vicinity of welding.
3. Before welding or cutting, warn those in close proximity who are not protected to wear proper clothing or goggles.
4. Remove any assembled parts from the component being welded that may become warped or otherwise damaged by the welding process.
5. Do not leave hot rejected electrode stubs, steel scrap, or tools on the floor or around the welding equipment. Accidents and/or fires may occur.
6. Keep a suitable fire extinguisher nearby at all times. Ensure the fire extinguisher is in operable condition.
7. Mark all hot metal after welding operations are completed. Soapstone is commonly used for this purpose.
8. Do not permit unauthorized persons to use welding or cutting equipment.
9. Check all the electrical connections before arc welding and do not use any naked or turn out wires.
10. During gas welding use trolley for moving gas cylinders from one place to another. Maintain correct pressure for different cylinders used during welding and never use expire cylinders during welding.

## **FIRE HAZARDS**

Fire prevention and protection is the responsibility of welders, cutters, and supervisors. Approximately six percent of the fires in industrial plants are caused by cutting and welding which has been done primarily with portable equipment.

1. During the welding and cutting operations, sparks and molten spatter are formed which sometimes fly considerable distances and fall through cracks, pipe holes, or other small openings in floors and partitions, starting fires in other areas which temporarily may go unnoticed. For these reasons, welding or cutting should not be done near flammable materials unless every precaution is taken to prevent ignition.
2. Hot pieces of base metal may come in contact with combustible materials and start fires. So care must be taken regarding this base metal after welding.
3. When welding or cutting parts of vehicles, the oil pan, gasoline tank, and other parts of the vehicle are considered fire hazards and must be removed or effectively shielded from sparks, slag, and molten metal.
4. Whenever possible, flammable materials attached to or near equipment requiring welding, brazing, or cutting will be removed. If removal is not practical, a suitable shield

of heat resistant material should be used to protect the flammable material. Fire extinguishing equipment, for any type of fire that may be encountered, must be present.

## SAFETY EQUIPMENTS & ITS APPLICATION

### HELMETS AND SHIELDS

The welder needs a helmet to protect his eyes and face from harmful light and particles of hot metal. The welding helmet is generally constructed of a pressed fiber insulating material. It has an adjustable headband that makes it usable by persons with different head sizes. To minimize reflection and glare produced by the intense light, the helmet is dull black in color. It fits over the head and can be swung upward when not welding. The chief advantage of the helmet is that it leaves both hands free, making it possible to hold the work and weld at the same time. A hand-held shield provides the same protection as the helmet, but is held in position by the handle. This type of shield is frequently used by an observer or a person who welds for a short period of time. The protective welding helmet has lens holders used to insert the cover glass and the filter glass or plate. Lenses are designed to prevent flash burns and eye damage by absorption of the infrared and ultraviolet rays produced by the arc. Face shields must also be worn where required to protect eyes.

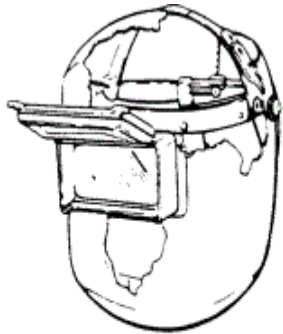

cutaway view of welding helmet

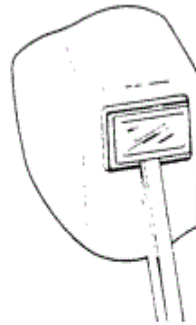

Hand held shield



CLEAR FACE SHIELD

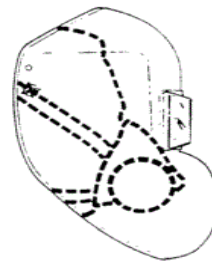

HELMET WITH RESPIRATOR

Fig. 3.1

## SAFETY GOGGLES

During all electric welding processes, operators must wear safety goggles to protect their eyes from weld spatter which occasionally gets inside the helmet. These goggles also protect the eyes from slag particles when chipping and hot spark when grinding. Contact lenses should not be worn when welding or working around welders. Tinted safety glasses with side shields are recommended, especially when welders are chipping or grinding. Those working around welders should also wear tinted safety glasses with side shields.



SAFETY GOGGLES

Fig. 3.2

## HAND GLOVES, SHOES AND APRON

Flameproof aprons or jackets made of leather, fire resistant material, or other suitable material should be worn for protection against spatter of molten metal, radiated heat, and sparks. A welder should wear leather leggings, leather full top shoes, and leather welding gloves fitting tightly upto the jacket sleeves.

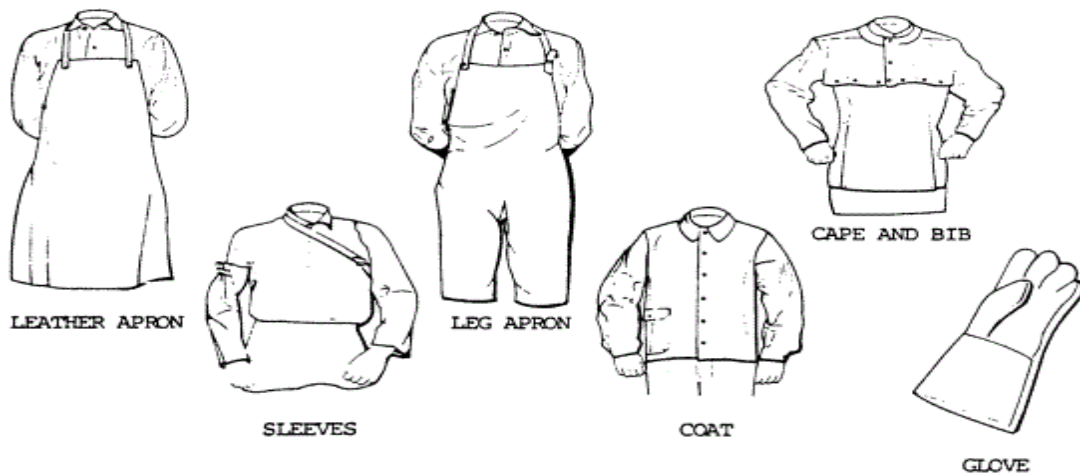

Fig. 3.3

## PROTECTIVE CLOTHING

Clothing should always be kept dry, including gloves. Capes or shoulder covers made of leather or other suitable materials should be worn during overhead welding or cutting operations.

Leather skull caps may be worn under helmets to prevent head burns. Woolen clothing should be worn instead of cotton since wool is not easily burned or damaged by weld spatter and helps to protect the welder from changes in temperature. Cotton clothing, if used, should be chemically treated to reduce its combustibility. All other clothing, such as jumpers or overalls, should be reasonably free from oil or grease.

## INTRODUCTION TO WELDING

Modern methods of welding may be classified under two broad headings: (1) plastic welding, and (2) fusion welding. They are also called pressure welding, and nonpressure welding respectively. In the plastic welding or pressure welding, the pieces of metal to be joined are heated to a plastic state and then forced together by external pressure. This procedure is used in forge welding, resistance welding, "thermit" welding etc in which pressure is required. In the fusion welding or non pressure welding, the material at the joint is heated to a molten state and allowed to solidify. This includes gas welding, arc welding, "thermit" welding, etc. in which pressure is not required.

**SOLID STATE WELDING:** - Interatomic bonds may be established by bringing atoms of two surfaces in close enough proximity to assure adhesion. Relative movement of the surfaces under pressure and controlled roughness are helpful in breaking through surface films. While theoretically no pressure would be required for bonding, in practice a certain normal pressure is necessary to assure conformity with the contacting surfaces. No heat is applied but still there is also a possibility of rise in temperature during solid state welding. In principle, however, any material can be bonded and solid state bonding is often applied when other technique fails. Solid state welding includes diffusion welding, ultrasonic welding, friction welding and explosive welding.

## TYPES OF WELDING PROCESSES

### 1. Gas welding

a). Oxy-acetylene b). Air-acetylene c). Oxy-hydrogen

### 2. Arc welding:

- |                  |                   |                        |
|------------------|-------------------|------------------------|
| a) Carbon arc    | d) Metal arc      | g) Gas metal arc       |
| b) Plasma arc    | e) Electro-slag   | h) Gas tungsten arc    |
| c) Submerged arc | f) Flux-cored arc | i) Atomic-hydrogen arc |

### 3. Resistance welding

- a) Butt
- b) Projection
- c) Spot
- d) Percussion
- e) Seam

### 4. Thermit welding

## 5. Solid state welding

a) Friction   b) Ultrasonic   c) Diffusion   d) Explosive

6. Newer welding: - a) Electron beam   b) Laser

## MATERIALS THAT CAN BE WELDED

The term “weldability” has been defined as the capacity of being welded into inseparable joints having specified properties such as definite weld strength, proper-structure, etc. This means, of course, that if a particular metal is to have good weldability, it must be welded readily so as to perform satisfactorily in the fabricated structure.

Weldability depends on one or more of five major factors: (1) melting point, (2) thermal conductivity, (3) thermal expansion, (4) surface condition, and (5) change in microstructure. Common materials that can be welded using various welding techniques are wrought iron, mild steel, medium carbon steel, high carbon steel, cast steel, stainless steel, tool steel, alloys steel, cast iron, aluminium, copper and its alloys, nickel and nickel alloys, etc.

## GAS WELDING

Gas welding is done by burning a combustible gas (fuel) with air or oxygen in a concentrated flame of high temperature. As with other welding methods, the purpose of the flame is to heat and melt the parent metal and filler rod of a joint. It can weld most common materials. Equipment is inexpensive, versatile and serves adequately in many job and general repair shops. Various gas combinations can be used for producing a hot flame for welding metals. Common mixture of gases is oxygen and acetylene, oxygen and hydrogen, oxygen and other fuel gas, and air and acetylene. The oxygen-acetylene mixture is used to a much greater extent than the other and has a prominent place in the welding industry.

## OXY-ACETYLENE WELDING

The process of Oxy-Acetylene Welding can be used for welding almost all metals and alloys used in engineering practice. The advantage of using Acetylene, instead of other fuels, with Oxygen is that it produces a comparatively higher temperature and also an Inert gas Envelope, consisting of carbon dioxide and water vapours, which prevents the molten metal from oxidation. The highest temperature that can be produced by a flame of oxygen and acetylene is nearly 3200°C. There are two systems of Oxygen-Acetylene Welding.

(i) **High Pressure System.** In this method both oxygen and acetylene are derived for use from High Pressure Cylinders.

(ii) **Low Pressure System.** In this system oxygen is taken as usual from a high pressure cylinder but acetylene is generated by the action of water on carbide (usually calcium carbide), in a Low Pressure Acetylene Generator.

This process is particularly suitable for joining metal sheets and plates having thickness of 2 to 50 mm. With material thicker than 15 mm, additional metal called filler metal is added to the weld in the form of welding rod.

The Composition of the filler rod is usually the same or nearly the same as that of the part being welded. To remove the impurities and oxides present on the surfaces of metal to be joined and to obtain a satisfactory bond a flux is always employed during the welding except mild steel which has more manganese and silicon that act as deoxidizing agent.

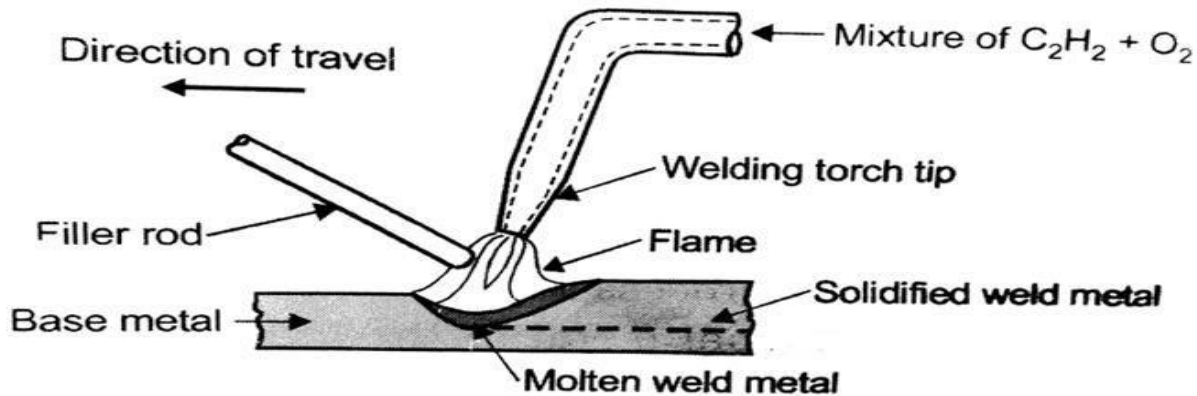

Fig. 3.4 oxy-acetylene welding

## WELDING TOOLS AND EQUIPMENTS

The most commonly used equipment for oxy-acetylene welding consists of the following.

**Welding torch:** -Also known as blow pipes.This is a tool for mixing oxygen and acetylene in correct proportion and burning the mixture at the end of a tip. These are available commercially in two general types: (1) equal pressure, and (2) injector type. The medium or equal-pressure welding torch is the more common of the two types of oxy-acetylene torches. The mixing chamber in the equal pressure torch allows both of the gases to flow together in equal amounts.

**Welding tip:** -It is that portion of the welding apparatus through which the gases pass just prior to their ignition and burning. There is a great variety of interchangeable welding tips differing in size, shape and construction. The tip sizes are governed by the diameter of the opening. The diameter of the tip opening used for welding depends upon the type of metal to be welded, such as whether it is stainless steel, iron, or brass, and the thickness of the metal to be welded.

**Pressure regulator:** - These are fixed just on the top of the gas cylinders and carry a reducing valve each. Gases from the High-pressure Cylinders are just passed through these regulators and then fed to the blowpipe (torch) after their pressure has been reduced to the desired extent by means of these valves. The pressure is regulated according to need by adjusting the spring pressure on the diaphragm by means of screw called Pressure Regulating screws.

**Regulator pressure for gas welding:** - The pressure required for gas welding depends on the thickness of the plates to be welded. For plates of thickness of about 1 to 25 mm, the regulator pressure in oxygen and acetylene, varies from 0.15 to 0.70 kgf/ cm<sup>2</sup> (15 to 70 kN/m<sup>2</sup>) ; and for plate thickness over 25 mm, the pressure of each gas is about 0.98 kgf/cm<sup>2</sup>(98 kN/m<sup>2</sup>). This is for high-pressure welding, but in the case of lows pressure welding, the oxygen pressure exceeds 0.98 kgf/cm<sup>2</sup> (98 kN/m<sup>2</sup>) and goes up to about 2 kgf/cm<sup>2</sup> (200 kN/m<sup>2</sup>) and acetylene pressure is 0.15kgf/cm<sup>2</sup> (15kN/m<sup>2</sup>).

**Hose and hose fittings:**-The hose for welding torches should be strong, durable, nonporous, and light. The most common method of piping both oxygen and acetylene gas is the reinforced rubber hose, which comes in black, green and red. Green is the standard color for oxygen hose, red for acetylene, and black hose for other industrially available welding gases. Special hose fittings, or connections, are provided for attachment to the torch and pressure regulators.

**Goggles, gloves and spark-lighter:**- Goggles fitted with coloured lenses are provided to protect the eyes from harmful heat and ultraviolet and infrared rays. Gloves are used to protect the hands from any injury. Spark-lighter provides a convenient and instant means for lighting the welding torch. In addition to the above requirements, welding rods and fluxes are also employed.



Fig. 3.5 Various Equipments of gas Welding

**Gas cylinders:**-The High Pressure Oxy-acetylene Welding and Cutting Equipment consists of two large steel Cylinders; one containing oxygen at high pressure and the other dissolved Acetylene, also at high pressure. Both these cylinders are usually painted with distinct colours on the outside surfaces. Oxygen cylinder in black and acetylene cylinder in maroon.

Oxygen is filled in the cylinder at a pressure of 125 kgs to 140 kgs per square centimeter (or 1800 lbs. p.s.i. to 2000 lbs. p.s.i.).A full cylinder has the weight of about 80 kg. To provide against dangerously excessive pressure, such as could occur if the cylinders were exposed to fire, every valve has a safety device to release the oxygen before there is any danger of rupturing the cylinders. Fragile discs and fusible plugs are usually provided in the cylinders valves in case it is subjected to danger.

Acetylene is compressed into these cylinders so as to dissolve in acetone and that is why it is usually termed as 'Dissolved Acetylene'. These cylinders are usually filled to a pressure of 16 kgs to 21kgs per sq cm (or 255 lbs p.s.i. to 300 lbs p.s.i. nearly).Dissolved Acetylene cylinder should be handled with enough care and should not be exposed to such conditions which may result in an appreciable rise in temperature. As far as possible, their shifting from one place to the other by hands should be avoided. For transporting those good Trolley of some standard make should be used.

**Welding rods:** Sufficient care should be taken in selecting a suitable Welding Rod or Filler Rod for welding a particular material. Always the best available quality of the rods should be selected as the cheaper qualities are likely to contain more impurities and they will result in the



production of an unsound Joint. A welding rod should possess the same or nearly same composition of its constituents as that of the metal which is to be welded.



Fig. 3.6 Various Equipments of gas Welding

**Fluxes:** Except for the common grades of mild-steel, a Flux is always necessary for successfully welding of different metals and alloys. Also, the flux should be lighter in comparison to the molten metal so that it may float on the top of this metal during the operation and may deposit on the upper surface of the solidified metal after cooling, so as to be chipped off after this.

**Other tools and equipments:** The other equipment needed in oxy-acetylene working includes keys for cylinder valves, spanners, screens, chipping hammer, wire brush etc. In addition a Trolley is needed to carry the oxygen and acetylene cylinders from one work place to the other.

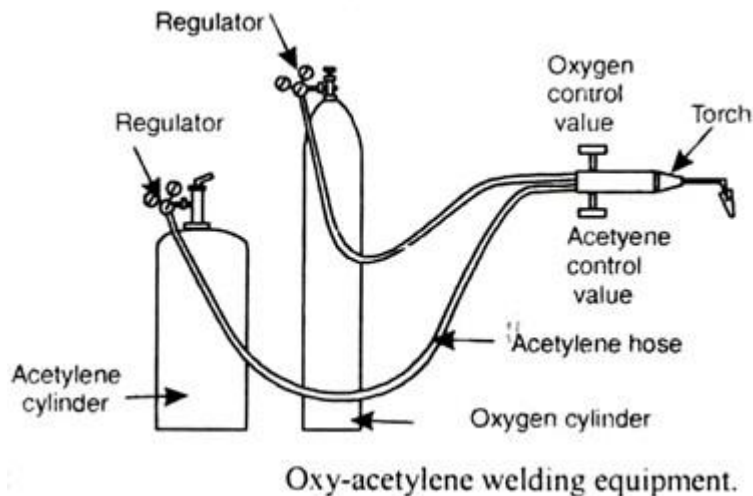

Fig. 3.7

## TYPES OF FLAMES

The correct adjustment of the flame is important for reliable works. When oxygen and acetylene are supplied to torch in nearly equal volumes, a neutral flame is produced. The heat is

generated in accordance with a pair of chemical reactions. The primary reaction occurs at the inner cone, where the temperature reaches between 3050 to 3450°C, the reaction in the inner cone is:



The secondary combustion process is in the outer envelope in which the flame attains a temperature around 2100°C near the inner cone and around 1250°C at the end point of the flame. The secondary combustion equation is:

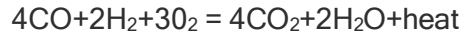

The temperature developed in the flame as a result of these reactions can reach 3200°C to 3300°C. This neutral flame is desired for most welding operations, but in certain cases a slightly oxidizing flame, in which there is an excess of oxygen or slightly carburizing flame, in which there is an excess of acetylene is needed.

A **neutral flame** has two definite zones: (1) a sharp brilliant cone extending a short distance from the tip of the torch, and (2) an outer cone or envelope only faintly luminous and of a bluish color. The first one develops heat and the second protects the molten metal from oxidation, because the oxygen in the surrounding atmosphere is consumed by the gases from the flame. The neutral flame is widely used for welding steel, stainless steel, Cast iron, copper, aluminum, etc.

A **carburizing flame** is one in which there is an excess of acetylene. This flame has three zones : (1) The sharply defined inner cone, (2) an Intermediate cone of whitish color, and (3) the bluish outer cone. The length of the intermediate cone is an indication of the proportion of excess acetylene in the flame.

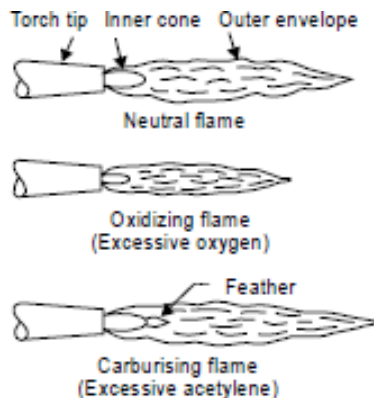

Fig. 3.8 Types of Flames

An **oxidizing flame** is one in which there is an excess of oxygen. This flame has two zones : (1) the small inner cone which has purplish tinge and (2) the outer cone or envelope. In the case of oxidizing flame the inner cone is not sharply defined as that of neutral or carburizing flame. This flame is necessary for welding brass. Proper adjustment of the flame leads to successful and

efficient welding. This adjustment can be made both in regard to the characteristics and the power of the flame by regulating the pressures of oxygen and acetylene.

## **APPLICATIONS OF GAS WELDING**

Repair works: One of the most common applications of gas welding is for repair works.

Fabrication of sheet metal: Thin to medium sheet metals are easily weld using gas welding.

Aircraft industry: Oxy-Acetylene welding is used in joining various aircraft parts.

*Weld ferrous and non-ferrous metals:* One of the great strengths of gas welding is that it can weld non-ferrous and ferrous metals together.

## **GENERAL SAFETY PRACTICES FOR GAS WELDING**

1. Always wear welding goggles while doing gas welding.
2. Always use the spark lighter to light the torch, never use a matchbox.
3. Do not allow blow pipe to heat cylinders, hoses or any other equipment.
4. Do not allow the hose to become excessively warm.
5. Do not remove the spanner used for operating the valve. Always keep it with the cylinders.
6. Secure cylinders in use, against falling, which may knock-off the valve.
7. To test the leakage in a valve or hose, use soap water but not a lighted match.

## **INTRODUCTION TO ELECTRIC ARC WELDING**

Arc welding is the most extensively employed method of joining metal parts. Here the source of heat is an electric arc. The arc column is generated between an anode, which is the positive pole of dc (direct current) power supply, and the cathode, the negative pole. When these two conductors of an electric circuit are brought together and separated for a small distance (2 to 4 mm) such that the current continues to flow through a path of ionized particles (gaseous medium), called plasma, an electric arc is formed. This ionized gas column acts as a high-resistance conductor that enables more ions to flow from the anode to the cathode. Heat is generated as the ions strike the cathode. Electrical energy is converted to heat energy. Approximately 1 kWh of electricity will create 250 calories (1000 J), the temperature at the centre of the arc being 6,000 to 7,000°C.

The heat of the arc raises the temperature of the parent metal which is melted forming a pool of molten metal. The electrode metal (in metal arc welding) or welding rod (in carbon-arc welding) is also melted and is transferred into the metal in the form of globules of molten metal. The deposited metal serves to fill and bond the joint or to fuse and build up the parent metal surface. Two-thirds of the heat is developed near the positive pole while the remaining one-third is developed near the negative pole. As a result, an electrode that is connected to the positive pole will burn away approximately 50 per cent faster than when it is connected to the negative pole.

## ARC WELDING EQUIPMENTS

1. A.C or D.C machine
2. Electrode
3. Electrode holder
4. Cables, cable connectors
5. Cable jug
6. Chipping hammer
7. Earthing clamps
8. Wire brush
9. Helmet
10. Safety goggles
11. Hand gloves
12. Apron, sleeves etc.

**Arc welding machine:** Both Alternating Current (A.C) and Direct Current (D.C.) are used for Arc Welding. When D.C. arc welding is to be employed the current is generated by a D.C Generator. This generator can be driven by means of an electric motor or by means of a petrol or diesel engine. Whether it is a motor generator set or an engine generator set, both can be either of Portable type or Stationary type. With the result, the D.C. Arc Welding Processes can be employed irrespective of the fact whether the main A.C. supply is available or not. In absence of the same an engine driven D.C. Generator set can easily be used. For A.C welding supply, transformers are predominantly used for almost all arc welding where mains electricity supply is available. They have to step down the usual supply voltage (200-400 volts) to the normal open circuit welding voltage (50-90 volts). A 100 to 200 A machine is small but portable and satisfactory for light manual welding. A 300 or 400 A size is suitable for manual welding of average work. Automatic welding requires capacities between 800 and 3000 A either in a single unit or a number of small units in parallel. For ac machine usually 60 Hz (hertz) is normal.

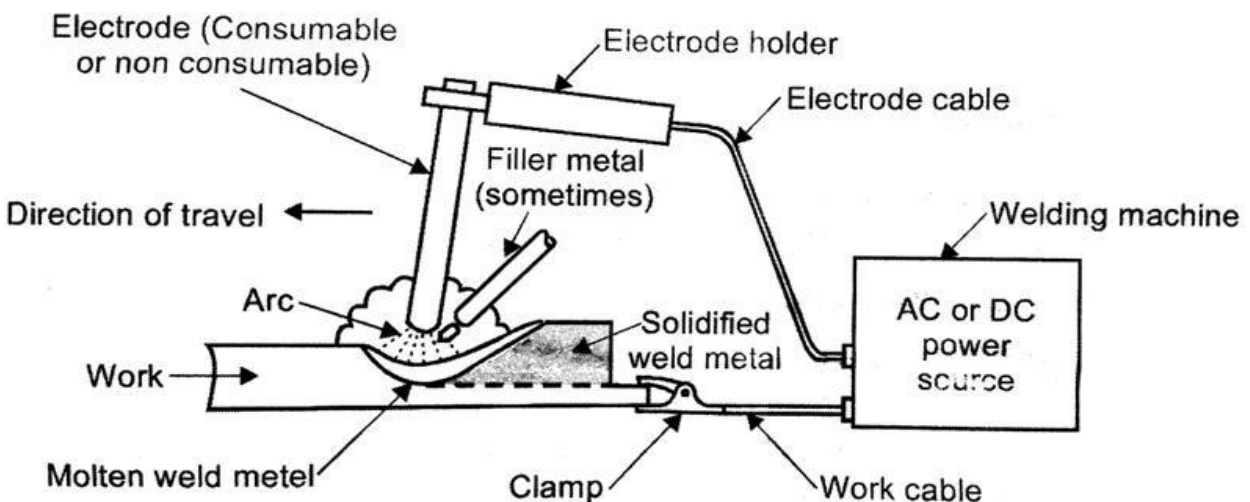
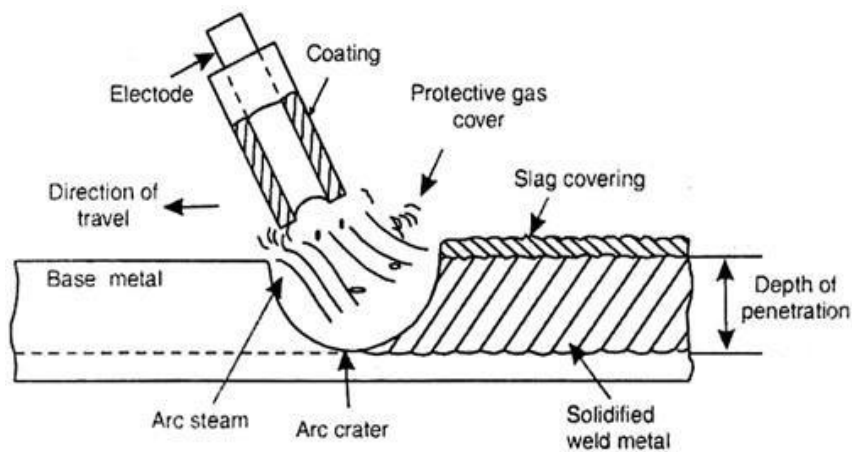

Fig. 3.9 Electric arc welding process

**Welding cables:** welding cable is used to connect the job with the earth line and the electrode holder with the main line (phase line). Highly insulated aluminium or copper cables are used for

the purpose. Two welding cables are required, one from the machine to the electrode holder and the other from the machine to the earthing clamp or to the work piece.

**Electrodes:** Both nonconsumable and consumable electrodes are used for arc welding. Nonconsumable electrodes may be made of carbon, graphite or tungsten which do not get consumed during the welding operation. Consumable electrodes may be made of various metals depending upon their purpose and the chemical composition of the metals to be welded. These consumable electrodes may be classed into bare and coated. Both bare and coated electrodes for hand arc welding are made in the shape of rods upto 12 mm in diameter and 450 mm long. Semi-automatic and automatic welding use electrode wire in coils. Soft steel wire containing 0.1 to 0.18 per cent carbon, and 0.0025 to 0.04 per cent phosphorus and sulphur is used for electrodes in welding carbon steel. Electrodes for alloy steel are made of low-alloy steel wire containing upto 0.25 per cent carbon.



Cut away view of the arc welding with a coated electrode.

Fig. 3.10

**Electrode holder:** It consists of a handle and jaw. The electrode holder is connected to the end of the welding cable and holds the electrode. It should be light, strong and easy to handle and should not become hot while in operation. The jaws of the holder are insulated.

**Earthing clamp:** It is connected to the end of the work cable and is clamped to the workpiece or welding table to complete the electric circuit. It should be Strong and durable and have a low resistance.

**Wire brush and chipping hammer:** A wire brush is used for cleaning and preparing the work for welding. A chipping hammer is used for removing slag formed on welds. One end of the head is sharpened like a cold chisel and the other, to a blunt, round point. It is generally made of tool steel.

## Arc welding Equipments



Fig. 3.11 Arc Welding Equipments

### ARC WELDING CURRENT AND VOLTAGE:

Open-circuit voltage (no load voltage), i.e., the voltage needed to strike the arc, is higher than the arc voltage in order to facilitate easy starting of the arc. With direct current (D.C), the open-circuit voltage must be at least 30 to 35V, while with alternating current (A.C) it should not be lower than 50 or 55V. Open circuit voltage usually ranges from 50 to 90V. The voltage falls after the arc is established. The voltage necessary for proper arc maintenance depends upon the composition of the electrode rod, its coating, the type of current, but the main factor is the length of the-arc. In general, arc voltage ranges 15 to 25V with the usual bare or lightly coated electrodes, from 20 to 40V with the usual covered electrodes, and upto 45V with some special electrodes.

### POLARITY IN ARC-WELDING

There is no fixed polarity at the terminals when using A.C. and they interchange in every cycle. Unlike A.C., in D.C. welding the electrode acts as one terminal and the job the other terminal (either +ve or -ve). The potential difference can be so adjusted that the heat developed at the positive terminal is higher (nearly 66 percent) and that on the negative terminal lower (nearly 33 percent) of the total heat evolved. Polarity is a very significant factor in all D.C. welding works. This polarity can be of two types:

- A. Straight Polarity. In this, the electrode forms the negative terminal and the work piece positive.
- B. Reverse Polarity. In this, the electrode forms the positive terminal and the work piece negative.

These two polarities are known as Electrode Negative and Electrode Positive respectively. Selection of correct polarity plays a significant role in obtaining a successful weld. It is only due to this factor that almost all the metals can be welded by using D.C. as many metals require

more heat to acquire the fusion state than the electrode used e.g. copper, and it is possible only through different polarities to have more heat on the job and less on the electrode.

## **PRECAUTIONS DURING ARC WELDING**

1. Check the welding machine to make sure that it is properly earthed and all leads are properly insulated.
2. Never look at the arc with the naked eye. The arc can burn eyes severely. Always use a faceshield or a helmet with window of coloured glass while welding.
3. Prevent welding cables from coming in Contact with hot metal, water, oil or grease. Avoid dragging the cables around sharp corners.
4. Ensure proper insulation of the cables and check the openings.
5. Always wear the safety hand gloves, apron and leather shoes.
6. Always turn-off the machine when leaving the work.
7. The space for the arc welding should be screened off from the rest of the building to safe guard other workmen from the glare of the arc.

## **THE MAIN TYPES OF ARC WELDING ARE:**

- a) Carbon arc
- b) Metal arc
- c) Metal inert gas arc (MIG)
- d) Gas tungsten arc (TIG)
- e) Atomic hydrogen arc
- f) Plasma arc
- g) Submerged arc
- h) Flux cored arc
- i) Electro slag, welding

## **APPLICATIONS OF ARC WELDING**

1. Aerospace and aircraft construction
2. Automotive industry
3. Auto body repairs
4. Used for most types of sheet metal welding
5. Fabrication of pressure vessels and steel structures
6. Shipbuilding
7. Construction industries, etc

## VARIOUS TYPES OF JOINTS AND END PREPARATION

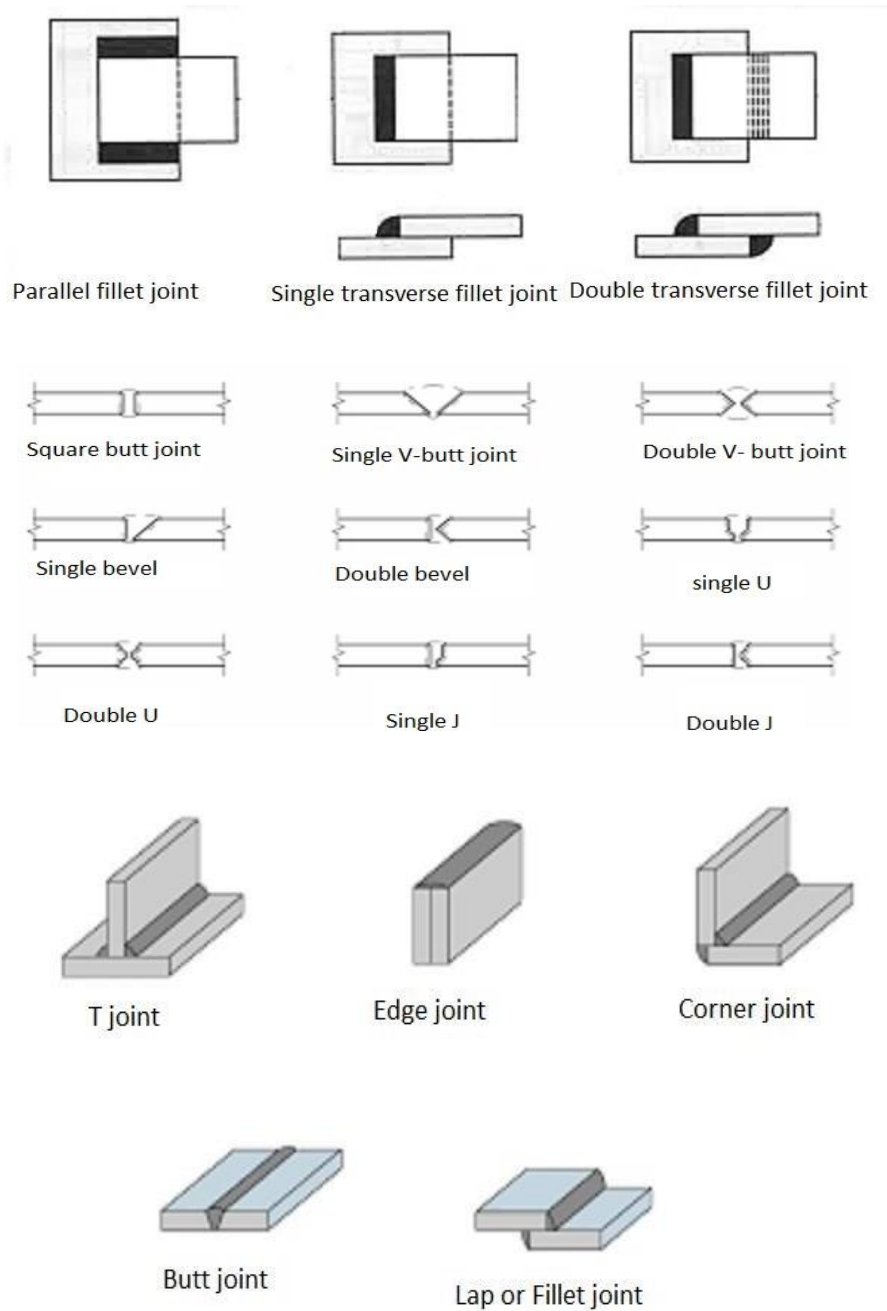

Standard weld joints

Fig. 3.12

The butt joint is used to join the ends or edges of two plates or surfaces located approximately in the same plane with each other. For thickness from 2 to 5 mm, the open square butt should be selected, but thickness upwards of 5mm, joints with edge preparation on one or both sides may be recommended.



The lap joint, as the name implies, is used to join two overlapping plates so that the edge of each plate is welded to the surface of the other. Common lap joints are single lap and double lap. The lap joint, however, may be employed for thickness less than 3 mm.

The T-joint is used to weld two plates or sections whose surfaces are approximately at right angle to each other. Plates or surfaces should have good fit-up in order to ensure uniform penetration and fusion. This is widely employed in thin walled structures particularly.

The corner joint is used to join the edges of two sheets or plates whose surfaces are at an angle of appropriately  $90^\circ$  to each other. It is common in the construction of boxes, tanks, frames, and other similar items. Welding can be done on one or both sides, depending on the position and type of corner joint used.

## EDGE PREPARATION

To obtain sound welds, good edge preparation is particularly essential, consisting in suitably beveling the edges, and carefully cleaning the faces to be welded from dust, sand, grit, oil and grease. Different edge preparation is particularly used in fusion welding processes for welding butt joints are : (1) square, (2) single-V, (3) double-V, (4) single-U, and (5) double-U. The preparation of edges depends upon the thickness of metal being welded.

Square butt weld may be used for thickness of from 3 to 5 mm. Before welding, the edges are spaced about 3 mm apart. Single-V butt welds are frequently used for metal over 8 mm thickness and up to about 16 mm thick. The edges forming the joint are beveled to form an included angle of  $70^\circ$  to  $90^\circ$  depending upon the welding technique to be used. Double-V butt welds are used on metals over 16 mm thick and where welding can be performed on both sides of the plate. Single and double-U butt welds are used on metals over 20 mm thick. These joints are having reliability and require less filler rod.

## WELDING DEFECTS

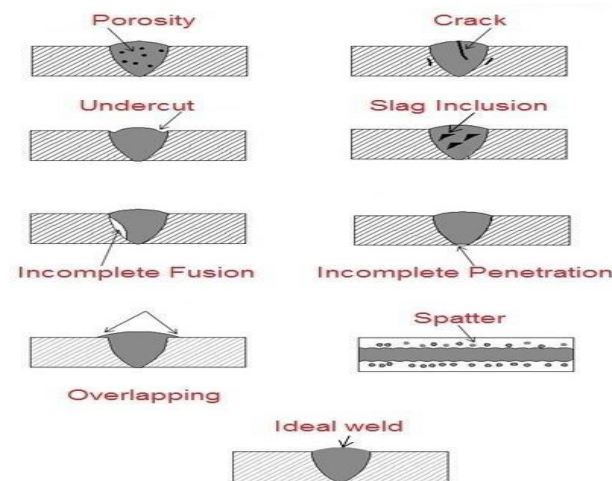

Fig. 3.13 Various Welding Defects

## JOB NO. 09

<b>DATE:</b>	<b>SECTION:</b>
<b>NAME:</b>	<b>COMPLETE:</b>
<b>REG. NO:</b>	<b>MARKS:</b>
<b>BRANCH:</b>	<b>Sign. Of Sr. Lect / Lecturer</b>

**AIM OF THE EXPERIMENT:** To prepare a lap joint through arc welding in flat position.

### OBJECTIVES OF THE EXPERIMENT:

- Set the job for flat position welding
- Maintain correct overlapping
- Tacking at proper positions
- Weld along the joint with correct arc length
- Maintain correct electrode angle
- Maintain uniform welding speed
- Use of proper welding technique

**RAW MATERIAL REQUIRED:** Two mild steel flat pieces of size 125mm×45mm×5mm each and M.S. electrodes.

### TOOLS AND EQUIPMENTS REQUIRED:

SL. NO	NAME OF EQUIPMENTS	SPECIFICATION/TYPE	QUANTITY
1	Arc welding transformer		
2	Electrodes		
3	Electrode holder		
4	Cable and cable connectors		
5	Chipping hammer		
6	Wire brush		
7	Welding screen or helmet		
8	Gloves		
9	Apron		
10	Fitting tools (steel rule, scribe, files, clamps)		

## JOB FIGURE:

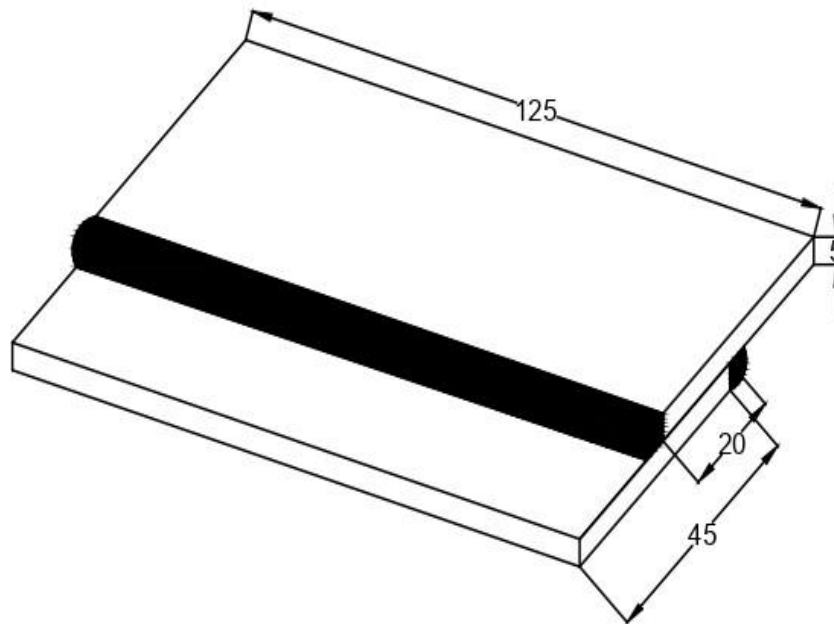

## PROCEDURE:

1. From M.S. flat of required thickness and width cut two pieces of 125 mm length each by using a hacksaw.
2. Set the two pieces, one over the other, such that the top piece overlaps the bottom piece by 20 mm.
3. Hold the pieces firmly together, in perfect alignment, by means of C-clamps on both ends.
4. Tack weld on both ends, where the fillets will be formed, and also in the middle of the length, if needed.
5. Set the tacked pieces in Flat Welding Position. Set the current at 120 Amps.
6. Select suitable electrode (say 3 mm diameter), hold it in electrode holder, and strike the arc.
7. Maintaining a short arc, deposit the root bead from one end to the other.
8. Using the chipping hammer and wire brush, clean the root bead thoroughly.
9. Then, replace the 3 mm diameter electrode by a 4 mm diameter electrode, increase the current suitably, strike the arc again and deposit the cover bead over the root bead from one end to the other.
10. Give wavy (side-to-side) movement to the electrode during welding in order to get better results.
11. Repeat the same operation on the other side of the joint to obtain similar fillet weld on both sides.

12. Using a chipping hammer, followed by a wire brush, clean the beads on both sides and inspect it visually to ensure that the beads are free of surface defects, the beads are uniform and fillets are of equal size.

**COMMON PRECAUTIONS:**

1. Always wear proper protective clothing and shoes during welding.
2. Use hand shield during welding to protect your eyes.
3. Use goggles during cleaning of the joint.
4. Maintain proper arc length.
5. Always use correct current and correct electrode size.
6. Never handle the hot job by hand, use tongs for this purpose.

**OBSERVATIONS:**

PARAMETERS	DESIRED OUTPUT	ACTUAL OUTPUT	ACCEPTED/REJECTED
Nature of overlapping	proper		
Quality of joint	Free from defects		
Finishing	Smooth		

**ASSIGNMENT QUESTIONS:**

1. What is welding and why it is done?
2. What do you mean by arc blow
3. Name any two welding defects.
4. What are the applications of arc welding?
5. What is “polarity” in arc welding?

## WRITING SPACE FOR ASSIGNMENTS

## JOB NO. 10

<b>DATE:</b>	<b>SECTION:</b>
<b>NAME:</b>	<b>COMPLETE:</b>
<b>REG. NO:</b>	<b>MARKS:</b>
<b>BRANCH:</b>	<b>Sign. Of Sr. Lect / Lecturer</b>

**AIM OF THE EXPERIMENT:** To prepare a butt joint (single-V) through electric arc welding

### OBJECTIVES OF THE EXPERIMENT:

- Set the job for square butt joint
- Tacking at proper positions
- Weld along the joint with correct arc length
- Maintain correct electrode angle
- Maintain uniform welding speed
- Use of proper welding technique

**RAW MATERIAL REQUIRED:** Two mild steel flat pieces of size 140mm×45mm×5mm each and M.S. electrodes.

### TOOLS AND EQUIPMENTS REQUIRED:

SL. NO	NAME OF EQUIPMENTS	SPECIFICATION/TYPE	QUANTITY
1	Arc welding transformer		
2	Electrodes		
3	Electrode holder		
4	Cable and cable connectors		
5	Chipping hammer		
6	Wire brush		
7	Welding screen or helmet		
8	Gloves		
9	Apron		
10	Fitting tools (Steel rule, scribe, files, etc)		

## JOB FIGURE:

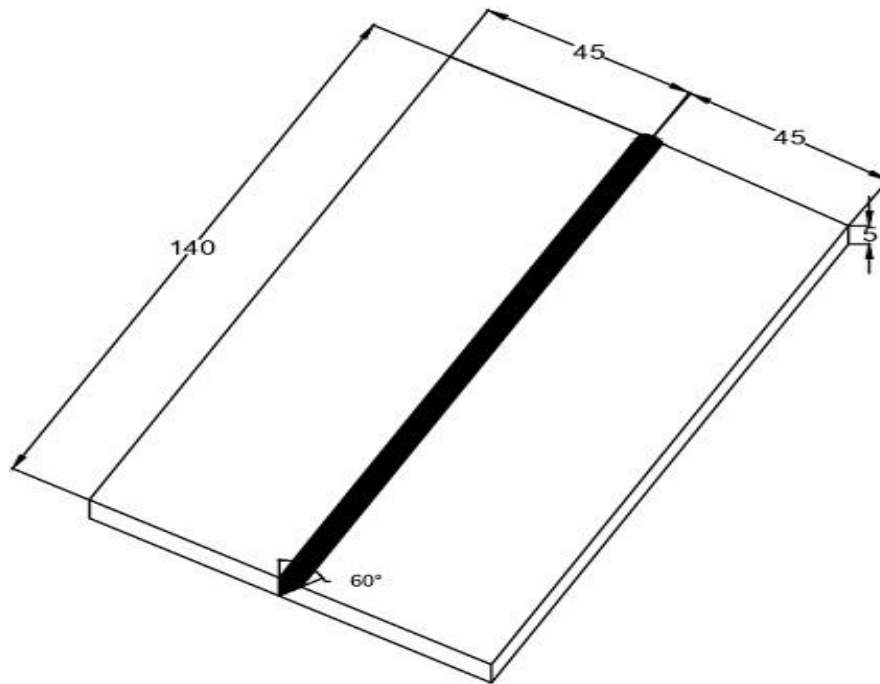

## PROCEDURE:

1. Cut the two pieces of required length from MS. Flat (of required width and thickness) by means of a hacksaw.
2. Cut the required bevel on the edges of both pieces to form the 60° 'V' when placed abutted.
3. Then, by means of filing, prepare the root faces.
4. Keep the two pieces in reverse position, i.e., the root gap on the top and 'V' groove in inverted position below.
5. Tack weld the two pieces along the root gap from both ends to a reasonable distance (say 12 mm).
6. Invert the tack welded pieces and place them in Flat Position to start welding.
7. Set proper current (120 Amps.) and lay the Root Bead using a 3 mm diameter M.S, Electrode. .
8. Clean the root bead and check the penetration.
9. Then using a 4 mm electrode and setting proper current, deposit the covering the (intermediate bead), at a uniform speed and a side-to-side (weaving) motion for the electrode.
10. Clean this intermediate (covering) bead by means of the chipping hammer and wire brush.
11. Then, using a 5 mm electrode and 220 Amps. Current, deposit the Final Covering Bead adopting the same weaving (side-to-side) motion for the electrode.

12. Finally clean the prepared joint thoroughly, using Chipping Hammer and Wire Brush, from both sides and check it for proper root penetration, distortion and visual surface defects, if any.

**COMMON PRECAUTIONS:**

1. Wear proper protective clothing, viz., apron, hand gloves etc., while welding.
2. Also use proper shield during welding.
3. While cleaning the Joint, use goggles for protection of eyes.
4. Strike and maintain proper arc throughout welding.
5. Always select and use proper current and correct electrode
6. Always use tongs to hold the hot workpieces.

**OBSERVATIONS:**

PARAMETERS	DESIRED OUTPUT	ACTUAL OUTPUT	ACCEPTED/REJECTED
Alignment of the job	proper		
Quality of joint	Free from defects		
Finishing	Smooth		

**ASSIGNMENT QUESTIONS:**

1. Name various tools and safety equipments used in arc welding?
2. What do you mean by fluxes?
3. What is the advantage of having different 'polarity'?
4. What are various arc welding methods?
5. What are the advantages of arc welding?



## WRITING SPACE FOR ASSIGNMENTS

## JOB NO. 11

<b>DATE:</b>	<b>SECTION:</b>
<b>NAME:</b>	<b>COMPLETE:</b>
<b>REG. NO:</b>	<b>MARKS:</b>
<b>BRANCH:</b>	<b>Sign. Of Sr. Lect / Lecturer</b>

**AIM OF THE EXPERIMENT:** To prepare a T-joint (fillet weld) through gas welding in flat position

### OBJECTIVES OF THE EXPERIMENT:

- Set the job for Tee joint.
- Set gas pressure according to nozzle size.
- Tacking at proper positions.
- Weld along the joint with correct arc length.
- Fusion welding using correct filler rod and nozzle size.
- Use of proper welding technique.

**RAW MATERIAL REQUIRED:** Two mild steel sheet (2mm thick) pieces, one measuring 120mm×50mm, and the other 120mm×45mm, and filler rods of proper sizes.

### TOOLS AND EQUIPMENTS REQUIRED:

SL. NO	NAME OF EQUIPMENTS	SPECIFICATION/TYPE	QUANTITY
1	H.P. Oxygen and Acetylene cylinders		
2	Relevant pressure regulators		
3	Hose pipes and fittings		
4	Welding torch, nozzles		
5	Gas welding table		
6	Try square, steel rule, scribe, files		
7	Goggles, gloves, apron, shoes		
8	Spark lighter		
9	Chipping hammer		
10	Wire brush, tongs		

## JOB FIGURE:

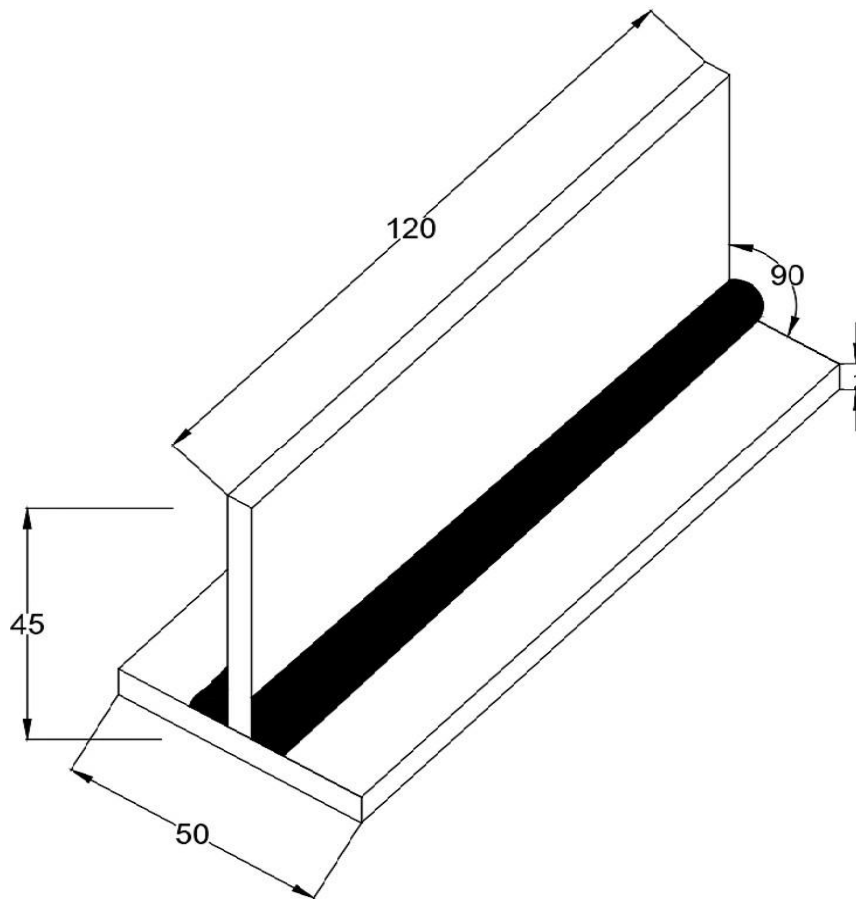

## PROCEDURE:

1. Measure, mark and cut the two pieces of required dimensions out of a 2 mm thick M.S. Sheet.
2. Square up the edges of vertical piece by means of filing.
3. Clean up the top surface of horizontal piece and the edge of vertical piece which are to be welded together.
4. Wear safety equipment and place the two pieces on the work table perpendicular to each other as shown in figure. With the help of a try square ensure that the angle between the two pieces is exactly  $90^\circ$
5. Hold them in this relative position firmly so that the included angle between them remains  $90^\circ$  throughout the welding operation.
6. Set up the gas welding plant, adjust the two regulators for required working pressures and fit proper nozzle to the blowpipe.
7. Start the acetylene flow, ignite the gas, start oxygen flow and regulate gas supply to obtain a neutral flame.

8. Using the filler rod and gas flame, tack weld at both ends of the joint and also along the length at suitable intervals.
9. Clean the tack welds and check the relative alignment of the two pieces.
10. Start welding at the right hand end and proceed leftwards, using Leftward Welding Technique, fusing the metal from both pieces at their junction and add more metal from filler rod to it to form the weld bead.
11. Terminate welding at the left hand end, put off the flame, place the blow pipe in position and clean the bead.
12. By visual inspection, check the uniformity of bead width, surface defects, if any, and proper penetration.

**COMMON PRECAUTIONS:**

1. Pressure regulators should be properly fitted on gas cylinders and set to deliver required working pressures of oxygen and acetylene.
2. Proper hose should be used for each gas.
3. Required safety equipment must be used during the operation.
4. Hot job should always be handled with tongs.
5. While starting the gas flow for lighting the flame, first start acetylene and then the oxygen. Similarly, while stopping the gas flame, close the oxygen valve first and then the acetylene valve.

**OBSERVATIONS:**

PARAMETERS	DESIRED OUTPUT	ACTUAL OUTPUT	ACCEPTED/REJECTED
Alignment of the job	proper		
Quality of joint	Free from defects		
Finishing	Smooth		

**ASSIGNMENT QUESTIONS:**

1. How many types of flames are there in gas welding?
2. Which flame is used for welding brass?
3. What are various tools and equipments in gas welding?
4. What is the colour of oxygen cylinder?
5. What are the advantages and applications of gas welding?

## WRITING SPACE FOR ASSIGNMENTS

# TURNING SHOP

## INTRODUCTION:

Turning is the machining process to bring the raw material to the required cylindrical shape and size by metal removal from the work surface. This is done by feeding a cutting tool against a rotating workpiece. This machine tool on which turning is carried out is called lathe.

A lathe is a machine tool that rotates a workpiece about an axis of rotation to perform various operations such as cutting, sanding, knurling, drilling, deformation, facing, and turning, with tools that are applied to the workpiece to create an object with symmetry about that axis

## WORKING PRINCIPLE:

The lathe is a [machine tool](#) which holds the workpiece between two rigid and strong supports called centers or in a chuck or face plate which revolves. The cutting tool is rigidly held and supported in a tool post which is fed against the revolving work. The normal cutting operations are performed with the cutting tool fed either parallel or at right angles to the axis of the work.

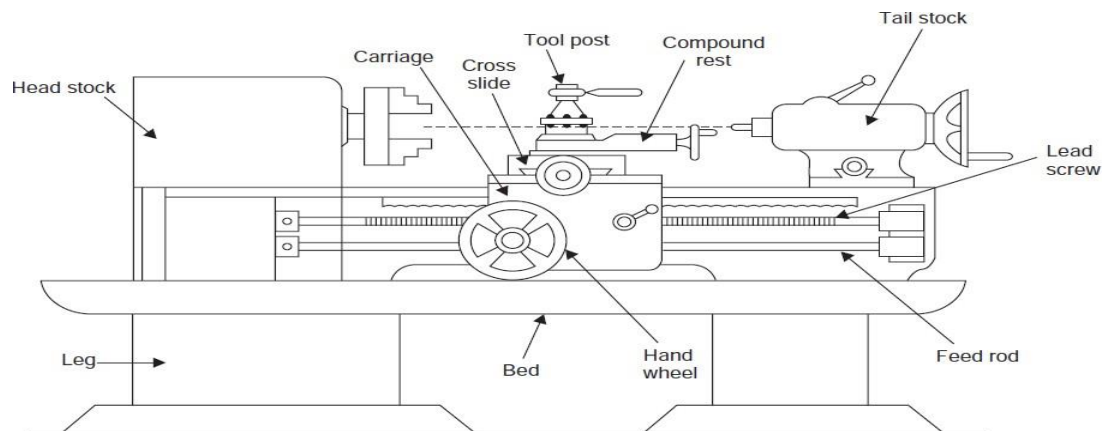

Fig. 4.1. Centre Lathe

Lathe removes considerable materials from rotating workpiece in the form of chips with the help of tools, which is feed against the rotating workpiece. The tool material should be harder than the workpiece.

## TYPES OF LATHE:

Lathe machines used in workshops can be divided into following types such as Centre, Production, Engine and Special Lathe.

**CENTRE LATHE:** The Centre Lathe is also known as SS and SC Lathe, which is used for surface and screw body. Various types of lathe machines are available under this type i.e., Hand Lathe, Bench Lathe, Foot Lathe, Tool and Engine Lathe.

## PRODUCTION LÁTHE:

Production Lathes are used when a particular job is to be produced in a large quantity. There are three kinds of production lathe machines such as Capstan Lathe, Turret Lathe and Multi Spindle Lathe.

## SPECIAL LATHE:

Special types of lathe machines are used for specific purposes. For example: Relieving Lathe, which are used for providing relief to milling cutters or tap. There are three types of lathe available under this section such as : Axial turning Lathe. Copying Lathe and Relieving Lathe.

## ENGINE LATHE:

Engine Lathe machines were normally used by fitters in the workshop when electric motors were not invented. These machines are operated with steam engines.

## MAIN PARTS OF THE LATHE:

The following are the main parts of the lathe such as :

- a. Head stock
- b. Tail Stock
- c. Carriage
- d. Cross Slide
- e. Compound Slide
- f. Bed
- g. Feed Shaft
- h. Legs
- i. Lead screw
- j. Quick Change Gear Box

## HEAD STOCK:

It is otherwise known as Live Centre. Head stock is fitted on the lathe bed on the left hand side of the lathe operator. The required gear and cone pulley is fitted in it for driving the lathe spindle. There are two types of head stock such as : All geared and Cone pulley head stock.

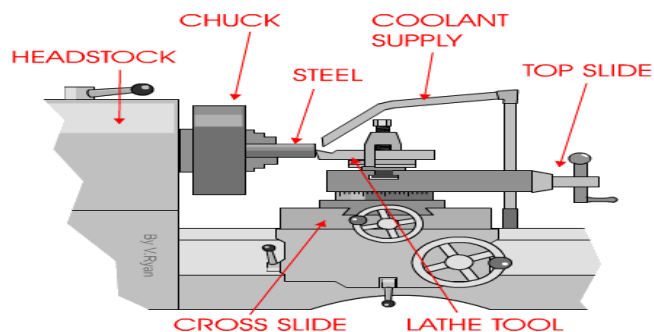
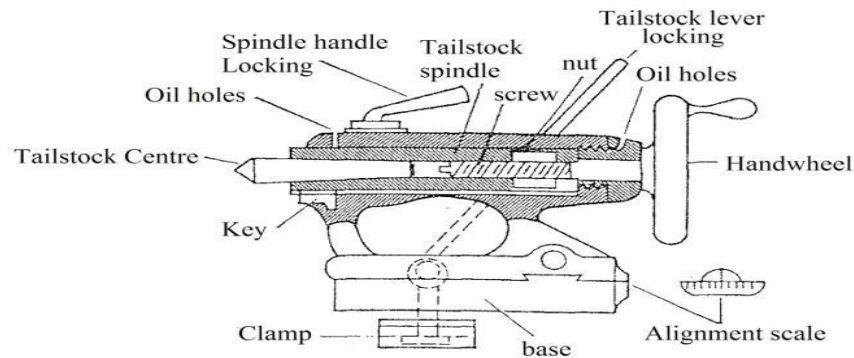

Fig. 4.2. Various Parts

## TAIL STOCK:

The tail stock is otherwise known as Dead Centre. It is fitted on the lathe machines bed, on the right hand side of the lathe operator. It can be moved to any desired space on the lathe bed in case of need. It is used for centre to centre turning of lengthy workpiece.



*Tailstock*

Fig. 4.3.

## CARRIAGE:

Literal meaning of "carriage" is to carry. Through carriage, a job can be brought in contact with the cutting tool or withdrawn from such a contact. It operates on bed ways between tail stock and head stock.

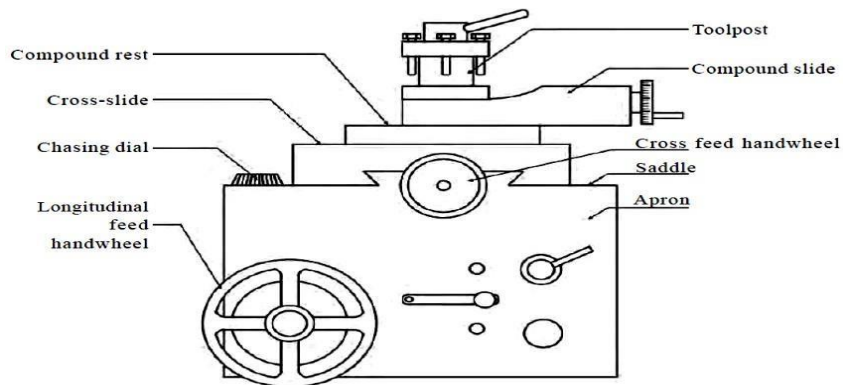

Fig. 4.4. Carriage

## CROSS SLIDE:

Cross Slide Provides the cutting motion of the tool. Cross Slide can be operated by hand or by the cross feed equipment. The alignment of the cross slide is perpendicular to the center of the lathe.



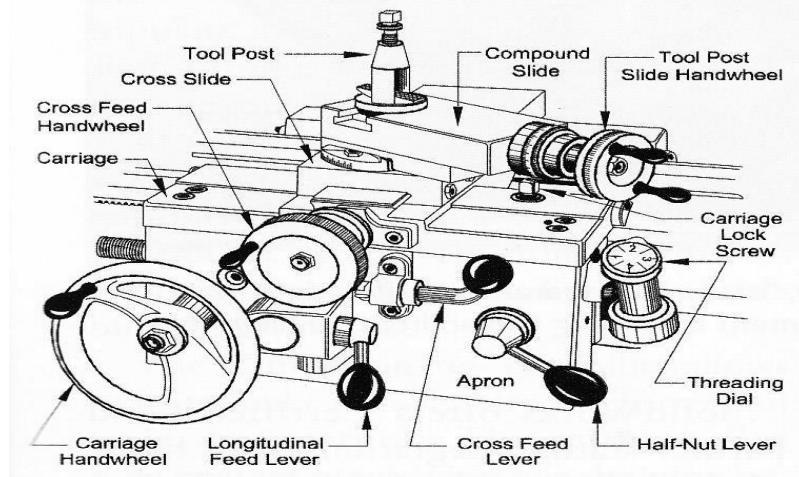

Fig. 4.5. Cross Slide

**COMPOUND SLIDE :**

It supports the tool post and cutting tools in its various positions. It may be swivelled on the cross slide to any angle in the horizontal planes, as it is being graduated suitably. It is necessary in turning.



Fig. 4.6. Compound Slide

**BED:**All the parts of the lathe machine are fixed to the bed. The saddles of the carriage slide on the beds. There are three types of beds such as : 'V' Bed, Flat Bed and Combination Bed.



Fig. 4.7. Bed

### **LEAD SCREW :**

It is a part of lathe machine, which is used for thread cutting operation. It has acme thread having angle  $29^\circ$ .



Fig. 4.8. Lead Screw

### **LATHE ACCESSORIES:**

- a. Lathe centre (Live Centre and Dead Centre)
- b. Chuck
- c. Catch Plated.
- d. Carriage
- e. Face Plate
- f. Steady Rest Mandrels

### **LATHE CENTRE:**

Centres are used to provide support to lengthy jobs on lathe machines,. These are used by fitting them into tail stock's spindle and head stock's spindle. These can be divided into two parts such as : Live Centre and Dead Centre.



Fig. 4.9. Lathe Centre

### LIVE CENTRE:

These are fitted in head stock's spindles. These are driven with the power of the machine.



Fig. 4.10. Live Centre

### DEAD CENTRE:

These centres are fitted in centre tail stock spindle and they provide support to the other end of the job.



Fig. 4.11. Dead Centre

### CHUCK:

Chuck is normally used to provide a strong grip to catch the job on the lathe machine. These are easily fitted on the threading to the end of head stock spindle. Generally these are two types such as : Three Jaw and Four Jaw Chuck.

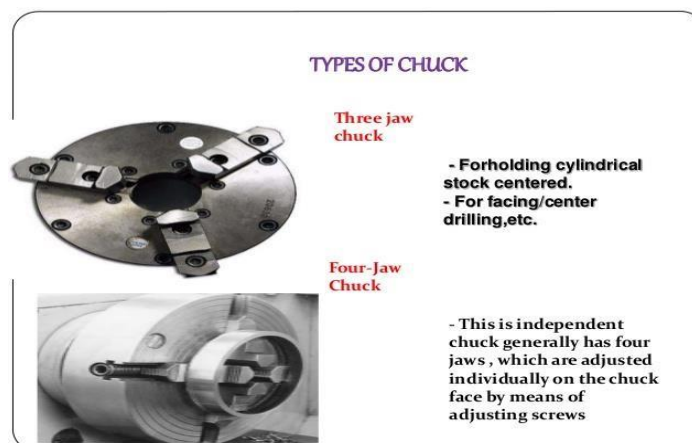

Fig. 4.12. Chuck

### CATCH PLATE:

The catch plate is also known as driving plate. It is a round ordinary plate of cast iron. Grooves facing each other are cut in this plate. Bent tail type job carrier is put in it and job is revolved. Threads exist in its centre and with their help head is fixed in the spindle.



Fig. 4.13.Catch Plate

### CARRIERS:

The carriers are also known as Dog. It is used with the catch plate. The job is tied in the carrier and fitted in the catch plate.



Fig. 4.14.Carriers

### FACE PLATE:

There are a number of jobs of such that these can not be fitted into the centres or clamped with the help of chucks for the purpose of turning. Such jobs are gripped by the face plate. This plate is also like the catch plate but it has a number of grooves on it.



Fig. 4.15.Face Plate

**ANGLE PLATE.**

- a) An angle plate is simply a cast iron plate with two faces planed at right angles to each other and having slots in various positions for the clamping bolts.
- b) It is always used with the face plate for holding such parts which cannot be clamped against the vertical surface of the face plate.

**STEADY REST :**

Steady rest is used for such cylindrically long jobs which are likely to get resilient at the time of turning. These are of two types such as: Fixed Steady Rest and Travelling Steady Rest.



Fig. 4.16. Steady Rest

**MANDRELS :**

- a) The lathe mandrel is a cylindrical bar with a centre hole at each end. It is used to hold hollow work pieces to machine their external surface.
- b) The work revolves with the mandrel which is mounted between the centres of the lathe. The various types of mandrels used for different classes of work are shown in Fig 4.17.



Fig. 4.17. Mandrels

**LATHE OPERATIONS :**

- a. Facing                      b. Parallel turning      c. Step turning      d. Counter turning      e. Form turning
- f. Chamfering                g. Cutoff                h. Threading            i. Boring                j. Drilling                k. Knurling

## **FACING**

The act of making equal and plain ends of a job in their actual length is called facing. Facing operation is carried out before any other operations are done on the job.

## **PARALLEL TURNING :**

Under the parallel turning, turning is done on the entire length of the job according to its maximum diameter.

## **STEP TURNING :**

To make smaller diameter on a plain round shaft than the diameter of the shaft is called step turning. Step turning is done after the facing and parallel turning operations.

## **TAPER TURNING:**

When one side of a job with parallel diameter, is cut turned completely or partially, to reduced its diameter, lathe operation is called taper turning. The angle of the taper is made according to the need, more or less internal or outer.

## **CONTOUR TURNING:**

In this operation of lathe machine the tool is not fed in a straight path. Instead the tool follows a contour. A contoured form is created in the turned part.

## **FORM TURNING:**

In this method a special shaped tool is used . The tool is inserted radially.

## **CHAMFERING :**

Tapering of a small part of a job at its edge or corner is known as chamfering: Chamfering is done after boring, knurling etc.

## **CUTOFF OR PARTING:**

In parting operation the tool is fed radially and the end part of the workpiece is cut off.

## **THREAD TURNING :**

In the workshops where there is need for cutting tapers frequently, taper turning is used. This attachment is fixed behind the carriage.

## **BORING:**

A single point tool head is fed linearly to the end of the workpiece (on the inside diameter) .

## **DRILLING**

Drilling and reaming is done by feeding the lathe tool along the axis of the rotating job part

## KNURLING:

Drawing slanting or square projecting lines on the surface of a job in order to have better grip is known as knurling. For this purpose a special knurling tool is used.

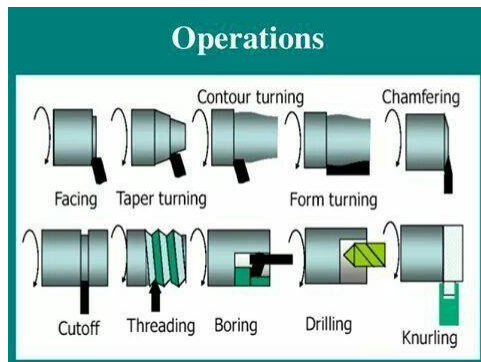

## JOB NO. 12

<b>DATE:</b>	<b>SECTION:</b>
<b>NAME:</b>	<b>COMPLETE:</b>
<b>REG. NO:</b>	<b>MARKS:</b>
<b>BRANCH:</b>	<b>Sign. Of Sr. Lect / Lecturer</b>

### AIM OF THE EXPERIMENT:

To prepare different types of Job Operation By S.S and S.C. Lathe

### OBJECTIVES OF THE EXPERIMENT :

- a. To know and identify the sliding surfacing and screw cutting (SS and SC) lathe machine.
- b. To know and identify the main parts of the SS and SC lathe machine.
- c. To know main functions of the different parts of the lathe machine.
- d. To know different operations such as facing, centering, plain turning, step turning taper turning and grooving etc.

### TOOLS AND EQUIPMENT REQUIRED

SERIAL NO	NAME OF EQUIPMENT	SPECIFICATION / TYPE	QUANTITY
01	Facing Tool		
02	Grooving Tool		
03	Tapping Tool		
04	Revolving Centre/Dead Centre		

### MEASURING INSTRUMENT :

- a. Slide caliper      b. Outside Caliper      c. Steel Rule

### Raw Material Required :

- a. M.S Round Rod : As per specified Given Job Diagram.



**JOB FIGURE :**

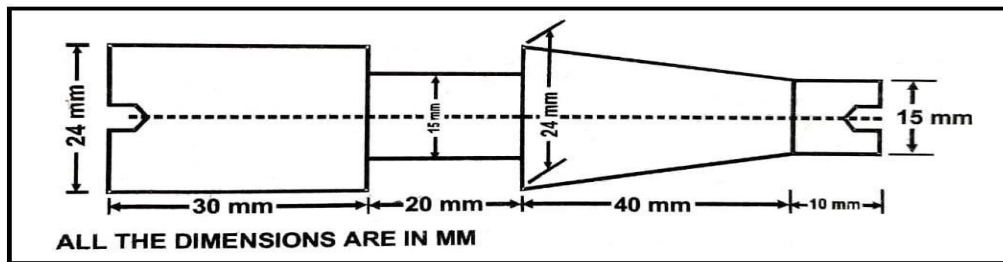

**PROCEDURE :**

1. At first study the drawing from the blackboard carefully.
2. Then cut the metal by the help of power hacksaw according to given specification.
3. Then hold the job by the help of chuck
4. Then facing the job by the facing tool.
5. Then drill center hole is mounted on the tail stock.
6. Set the job between chuck and tail stock.
7. Then grooving the job according to the required dimension.
8. Then tapering the job by the tapering tool.
9. Then finished the job according to the required dimension.

**OBSERVATION :**

**Tolerance : +0.25mm.**

	DESIRED DIMENSION IN mm	ACTUAL DIMENSION IN mm	DEVIATION FROM ALLOWABLE TOLERANCE	REASONS FOR DEVIATION
Maximum Dia of Taper				
Minimum Dia of Taper				
Groove Dia				
Length of the Job				

## **CONCLUSION :**

Explain the reasons for deviation from the given specification of the finished job. Suggest methods for improvement of quality of the job.

## **ASSIGNMENT QUESTIONS**

1. Draw the job sketch.
2. Is it possible to hold the job with the help of chuck ?
3. Write down the different types of chuck ?
4. What do you mean by taper ?
5. Write down the different types of taper?
6. What is the difference between hollow spindle and solid spindle ?
7. What is the difference between live centre and dead centre ?
8. What is the difference between revolving centre and dead centre ?
9. What is the difference between Universal chuck and Independent chuck ?
10. What are the different angles on lathe cutting tools ?
11. What are the jobs that can be done on a lathe machine ?
12. What is meant by speed, cutting speed and feed ?

**WRITTING SPACE FOR ASSIGNMENT**

## CNC MILLING/LATHE MACHINE

A Milling Machine is a machine tool used for the shaping of metal and other solid material. Milling machines exist in two basic forms: horizontal and vertical, which terms refer to the orientation of the cutting tool spindle.

Milling machines can perform a vast number of operations, some very complex, such as slot and keyway cutting, planing, drilling, diesinking, rebating, routing, etc. Cutting fluid is often pumped to the cutting site to cool and lubricate the cut, and to sluice away the resulting swarf.

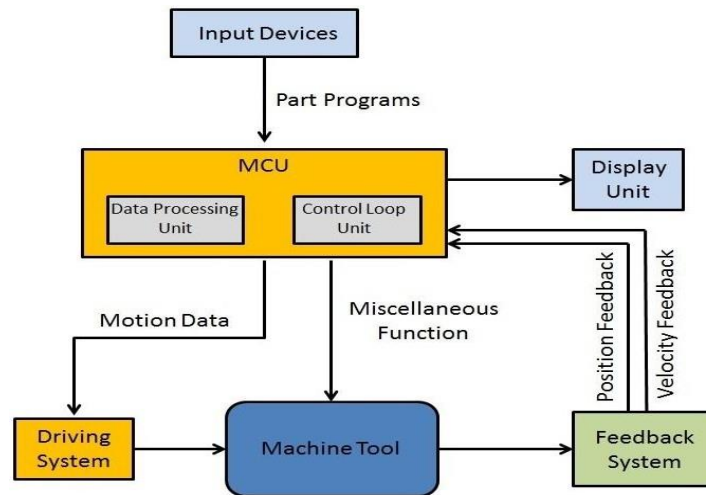

Fig. 5.1.CNC Circuit Diagram

### Types of CNC Milling Machine :

CNC Milling machines will nearly always use SK (or ISO), CAT, BT or HSK tooling. SK tooling is the most common in Europe, while CAT tooling, sometimes called V - Flange Tooling, CAT tooling comes in a range of sizes designated as CAT - 30, CAT - 40, CAT -50, etc.

### Machining Operations :

The three principal machining processes are classified as turning, drilling and milling. Other operations falling into miscellaneous categories include shaping, planing, boring, broaching and sawing.

- Turning operations are operations that rotate the workpiece as the primary method of moving metal against the cutting tool.
- Milling operations are operations in which the cutting tool rotates to bring cutting edges to be against the workpiece.
- Drilling operations are operations in which holes are produced or refined by bringing a rotating cutter with cutting edges at the lower extremity into contact with the workpiece.

- Miscellaneous operations are operations that strictly speaking may not be machining operations in that they may not be swarf producing operations but these operations are performed typical machine tool. Burnishing is an example of a miscellaneous operation.

### **Types of Machining Operation :**

There are many kinds of machining operations, each of which is capable of generating a certain part geometry and surface texture. In turning, a cutting tool with a single cutting edge is used to remove material from a rotating workpiece to generate a cylindrical shape. The speed motion in turning is provided by the rotating workpart, and the feed motion is achieved by the cutting tool moving slowly in a direction parallel to the axis of rotation of the workpiece.

Drilling is used to create a round hole. It is accomplished by a rotating tool that is typically two cutting edges. The tool is fed in a direction parallel to its axis of rotation into the workpart to form the round hole.



Fig. 5.2.CNC Lathe

In Boring, the tool is used to enlarge an already available hole. It is a fine finishing operation used in the final stages of product manufacture.

In Milling, a rotating tool with multiple cutting edges is moved slowly relative to the material to generate a plane or straight surface. The direction of the feed motion is perpendicular to the axis of rotation. The speed motion is provided by the rotating milling cutter. The two basic forms of milling are :**Peripheral and Face milling**

Other conventional machining operations include shaping, planing, broaching and sawing. Also, grinding and similar abrasive operations are often included within the category of machining.

## **Cutting Tool (Machining):**

A cutting tool has one or more sharp cutting edges and is made of a material that is harder than the work material. The cutting edge serves to separate chip from the parent work material. Connected to the cutting edge are the two surfaces of the tool such as: Rake Face and Flank.

### **Rake Face :**

The Rake Face which directs the flow of newly formed chip, is oriented at a certain angle is called the rake angle “+/-”. It is measured relative to the plane perpendicular to the work surface. The rake angle can be positive or negative.

### **Flank :**

The flank of the tool provides a clearance between the tool and the newly formed worksurface, thus protecting the surface from abrasion, which would degrade the finish. This angle on the work surface and the flank surface is called the relief angle. There are two basic type cutting tools such as : Single Point Tool and Multiple-cutting-edge Tool.

### **Shape :**

Several standard shapes of milling cutter are used in industry today, which are explained in more detail below.

### **Flutes / Teeth:**

The flutes of the milling bit are the deep helical grooves running up the cutter, while the sharp blade along the edge of the flute is known as the tooth. The tooth cuts the material, and chips of this material are pulled up the flute by the rotation of the cutter.

### **Helix Angle:**

The flutes of a milling cutter are almost always helical. If the flutes were straight, the whole tooth would impact the material at once, causing vibration and reducing accuracy and surface quality.

### **Center Cutting :**

Some milling cutters can drill straight down (plunge) through the material, while others cannot. This is because the teeth of some cutters do not go all the way to the centre of the end face.

### **Roughing or Finishing :**

Different types of cutter are available for cutting away large amounts of material, leaving a poor surface finish (roughing), or removing a smaller amount of material, but leaving a good surface finish (finishing). A roughing cutter may have serrated teeth for breaking the chips of material into smaller pieces.

## Coatings :

The right tool coatings can have a great influence on the cutting process by increasing cutting speed and tool life, and improving the surface finish, Polycrystalline Diamond (PCD) is an exceptionally hard coating used on cutters which must withstand high abrasive wear.

## Shank:

The shank is the cylindrical (non-fluted) part of the tool which is used to hold and locate it in the tool holder. A shank may be perfectly round, and held by friction, or it may have a Weldon Flat.

## Types of CNC Milling Machine :

The different types of CNC milling machines are : End mill, Slot drill, Roughing end mill, Ball nose cutter, Slab mill, HSS slab mill, Side-and-face cutter, Side and face cutter, Involute gear cutter.

## End Mill :

End mills (middle row in image) are those tools which have cutting teeth at one end, as well as on the sides. The words end mill are generally used to refer to flat bottomed cutters, but also include rounded cutters (referred to as ball nosed) and radiused cutters (referred to as bull nose, or torus). They are the most common tool used in a vertical mill.

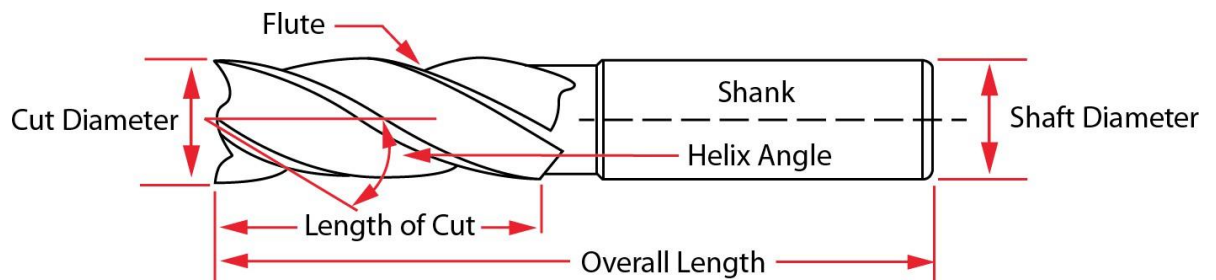

Fig. 5.3.End Milling Cutter

## Slab Mill :

Slab mills are used either by themselves or in gang milling operations on manual horizontal or universal milling machines to machine large broad surfaces quickly. They have been superseded by the use of carbide-tipped face mills which are then used in vertical mills or machining centres.

## Side and Face Cutter :

The side-and-face cutter is designed with cutting teeth on its side as well as its circumference. They are made in varying diameters and widths depending on the application. The teeth on the side allow the cutter to make unbalanced cuts (cutting on one side only) without deflecting the cutter as would happen with a slitting saw or slot cutter (no side teeth).

## Hob:

These cutters are a type of form tool and are used in hobbing machines \*to generate gears. A cross section of the cutters tooth will generate the required shape on the workpiece, once set to the appropriate conditions (blank size). A hobbing machine is a specialised milling machine.

## Face Mill:

A face mill consists of a cutter body (with the appropriate machine taper) that is designed to hold multiple disposable carbide or ceramic tips or inserts, often golden in color. The tips are not designed to be resharpened and are selected from a range of types that may be determined by various criteria, some of which may be: tip shape, cutting action required, material being cut.

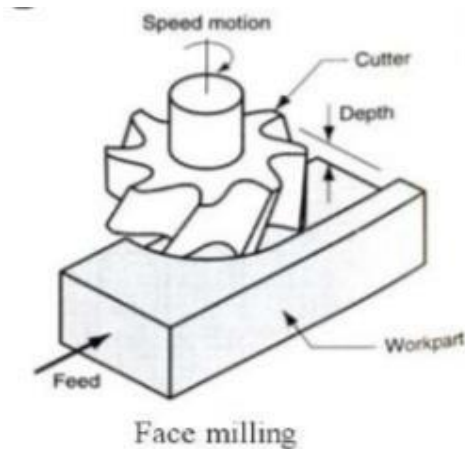

Fig. 5.4

## CNC LATHE:

CNC lathes are rapidly replacing the older production lathes (multispindle, etc) due to their ease of setting and operation. They are designed to use modern carbide tooling and fully utilize modern processes. The part may be designed and the toolpaths programmed by the CAD/CAM process, and the resulting file uploaded to the machine, and once set and trialled the machine will continue to turn outparts under the occasional supervision of an operator.

The machine is controlled electronically via a computer menu style interface, the program may be modified and displayed at the machine, along with a simulated view of the process. The setter/operator needs a high level of skill to perform the process, however the knowledge base is broader compared to the older production machines where intimate knowledge of each machine was considered essential. These machines are often set and operated by the same person, where the operator will supervise a small number of machines (cell).