

**A Laboratory manual
For
POWER STATION ENGINEERING LAB (PR- 2)**

**In accordance to syllabus
By S.C.T.E & V.T, Odisha
Semester – 6th**

DEPARTMENT OF MECHANICAL ENGINEERING



GOVERNMENT POLYTECHNIC, MAYURBHANJ

ODISHA – 757049

Affiliated to S.C.T.E & V.T, Odisha and A.I.C.T.E,

New Delhi

SYLLABUS

Pr 2. POWER STATION ENGINEERING LAB

Name of the Course: Diploma in MECHANICAL ENGINEERING			
Course code:		Semester	6th
Total Period:	60	Examination	3 hrs
Practical periods:	4 P/W	Sessional	25
Maximum marks:	75	End Semester Examination:	50

COURSE OBJECTIVES

At the end of the course the students will be able to

List of Practical

Experiment 01-To study the modern steam power plant with model.

Experiment 02-To determine the various efficiencies of steam turbine.

Experiment 03-To study the cooling tower.

Experiment 04-Study of jet condenser.

Experiment 05-Study of De-level turbine.

Experiment 06-To study the spring loaded safety valve.

Experiment 07-To study the following steam generators (boilers)models.

- a) Lancashire boiler.
- b) Cornish boiler.
- c) Babcock & Wilcox Boiler.
- d) Vertical water tube boiler.

EXPERIMENT NO : 01

AIM OF THE EXPERIMENT:

To study the modern steam power plant with model.

OBJECTIVES:

1. Study about the layout of steam power plant.
2. Study about the rankine cycle and different components steam power plant.

THEORY:

1. Modern Steam Power Plant and its Operating Cycle.

The general layout of the modern power plant consists of mainly four circuits which are

- ❖ Coal and ash circuit.
- ❖ Air and gas circuit.
- ❖ Feed water and steam flow circuit.
- ❖ Cooling water circuit.

A thermal power station using steam as working fluid works basically on the Rankine Cycle. Steam is generated in a boiler, expanded in a prime mover and condensed in a Condenser and fed into the boiler again with the help of pump. However, in practice, there are numerous modifications and improvements in this cycle with the aim of affecting heat economy and to increase the thermal efficiency of the plant.

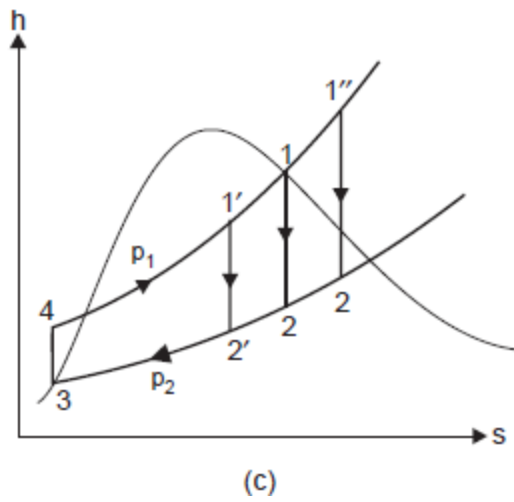
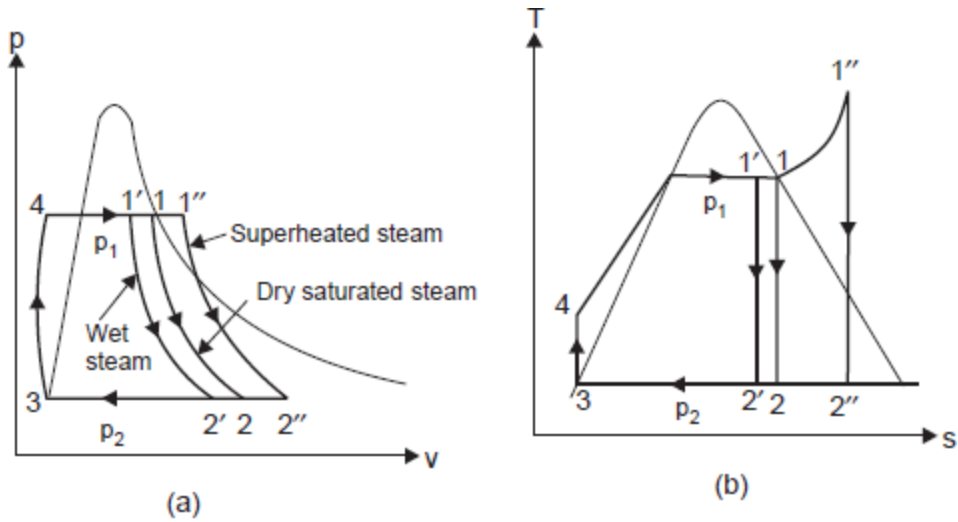

P-V, T-S and H-S diagram of simple Rankine cycle

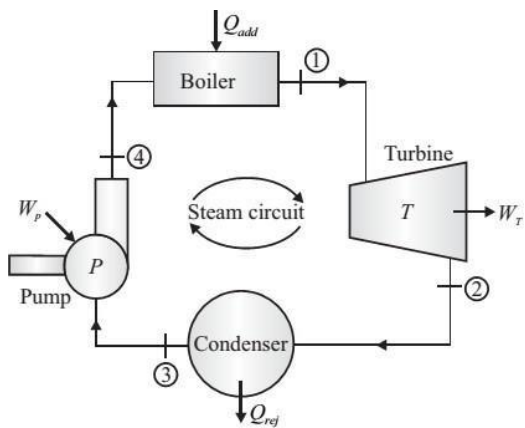

Simple Rankine cycle

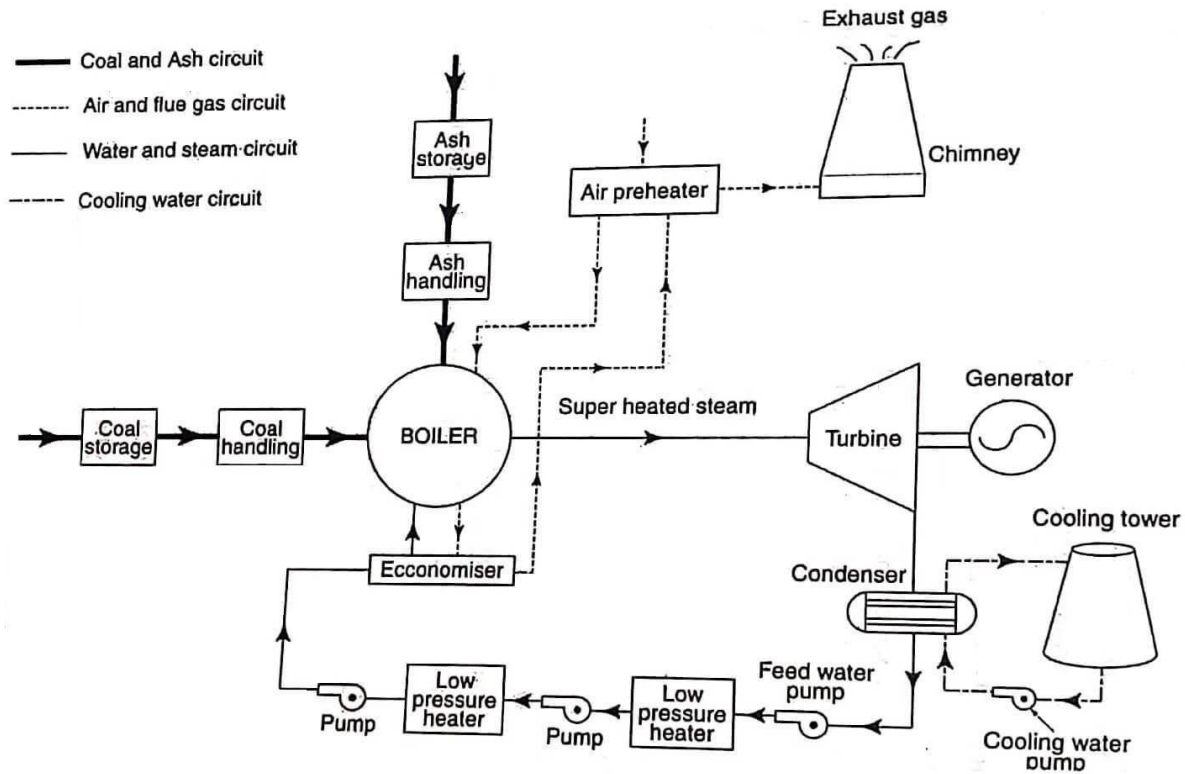

Steam power plant layout with its different circuits.

Coal and Ash Circuit

- Fuel i.e. coal, from the storage is fed to the boiler through feeding device, which consists of conveyor belt, crushing mill etc. and is called as coal handling plant. Ash produced as a result of combustion of coal collects at the back of the boiler and is removed to ash storage through ash handling equipment.

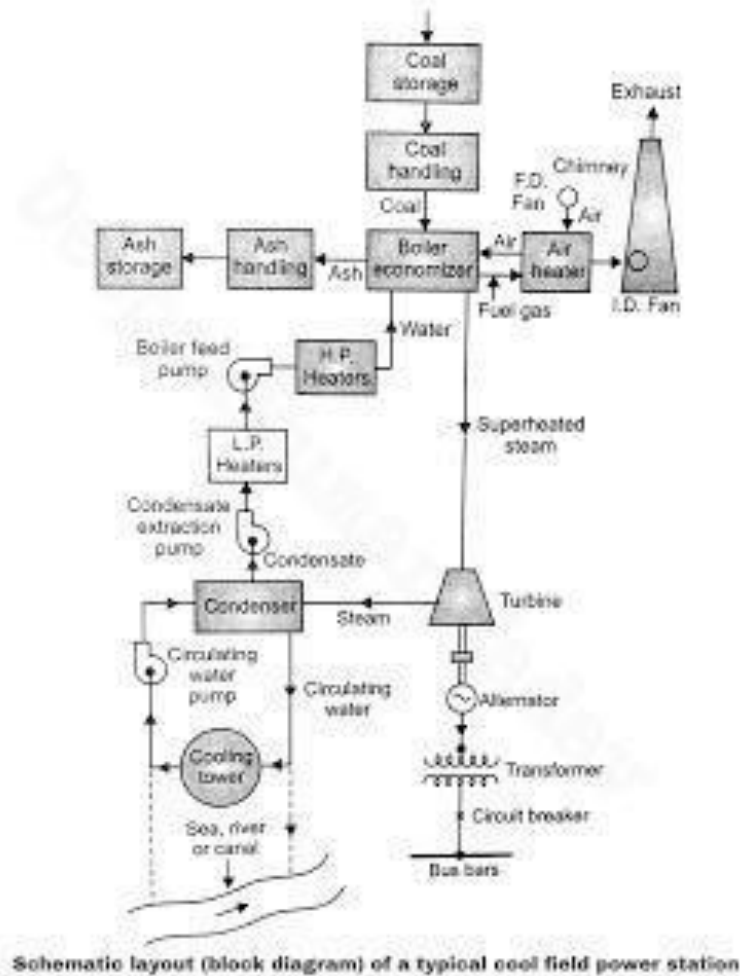

Air and Flue Gas Circuit

- Atmospheric air is supplied for combustion of coal in the boiler, through the action of Forced Draught (F.D.) fan or Induced Draught (I.D.) fan. The air, before being supplied to the boiler, passes through air preheater where it is heated by the heat of flue gases, which then passes to the chimney.
- The flue gases first pass around the boiler tubes and superheater tubes in the furnace, thereafter they pass through dust collector or dust precipitator, and then pass through economizer.
- At the end they are exhausted to the atmosphere through air preheater.

Feed Water and Steam Circuit

- The steam from turbine is condensed in the condenser, then it is heated in a closed feed water heater by means of extracted steam from the low pressure extraction point of the turbine.
- This heated water then passes through evaporator and few more water heaters before it is made to go to the boiler through the economizer.
- The reduced quantity of water is made up by adding water in the feed water system.

- Raw water from river or canal system passes through evaporator, is heated to steam and condensed into water in the evaporator and then passes through feed water pump into the feed water system in the boiler. Refer Figure.

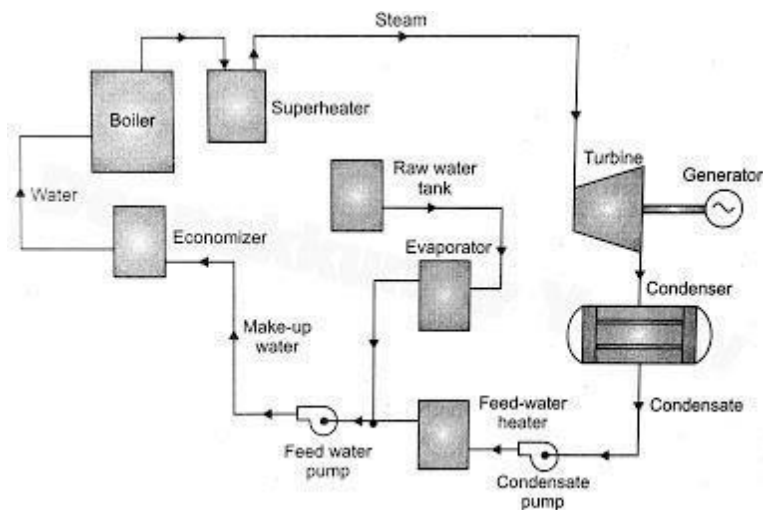

Feed Water and steam flow circuit for a Boiler turbine unit

- In the boiler drum and tubes water circulates, steam which contains particles of water from the boiler drum is further heated in the superheater before used for turbines.
- The steam then expands in the high pressure turbine and is taken to the reheat boiler where its temperature is increased or it is superheated and then passed to low pressure turbine, from this turbine it is exhausted through the condenser into the hot well.

Cooling Water Circuit

- Ample quantity of cooling water is required to condense the steam from turbines in the condenser and maintaining low pressure in it.
- If river or canal is nearby, cooling water may be taken from the upper side of the river or canal and after passing it through the condenser may be discharged to the lower side of the river or canal; such a system will be possible only when ample water is flowing through the river or canal throughout the year.
- When sufficient quantity of water is not available, water from the condenser may be used either in a cooling pond or cooling towers and reused.
- The quantity of water reduced in the cycle is made up by other sources of water.

CONCLUSION:

Practical related questions:

1. Explain Rankine cycle with its efficiency.
2. Explain different circuits of modern steam power plant.
3. Draw layout of modern thermal power plant.
4. Explain various site selection criteria required to consider for steam power plant.

Space for answer

EXPERIMENT NO : 02

AIM OF THE EXPERIMENT :

To determine the thermal efficiency of a steam turbine and evaluate its performance

APPARATUS REQUIRED :

SI no	Equipment	Specification	Quantity
01	Steam turbine		1

Steam turbine

In the steam turbine, the steam is expanded to a lower pressure providing shaft power to drive a generator or run a mechanical process. There are two basic types of steam turbine according to blade design: 1. Impulse turbine In this type, steam at high velocity hits the turbine blades and rotates the turbine 2. Reaction turbine In this type, steam passes through the blades which are designed like air foil and there is pressure difference between 2 sides of the blade and this causes the shaft to rotate. Their detail is given below: ➤ The difference between these two designs is shown in following figure:

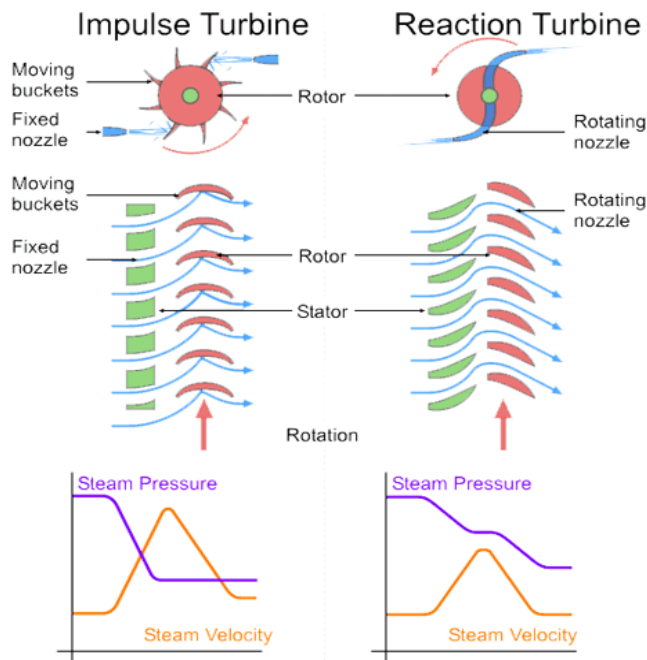

- In Impulse turbines, the steam jets are directed at the turbine's bucket shaped rotor blades where the pressure exerted by the jets causes the rotor to rotate and the velocity of the steam to reduce as it imparts its kinetic energy to the blades. The next series of fixed blades reverses the direction of the steam before it passes to the second row of moving blades.
- In Reaction turbines, the rotor blades of the reaction turbine are shaped more like airfoils, arranged such that the cross section of the chambers formed between the fixed blades diminishes from the inlet side towards the exhaust side of the blades. The chambers between the rotor blades essentially form nozzles so that as the steam progresses through the chambers its velocity increases while at the same time its pressure decreases, just as in the nozzles formed by the fixed blades.
- The stationary nozzles accelerate the steam to high velocity by expanding it to lower pressure. A rotating bladed disc changes the direction of the steam flow, thereby creating a force on the blades that, because of the wheeled geometry, manifests itself as torque on the shaft on which the bladed wheel is mounted. The combination of torque and speed is the output power of the turbine. A reduction gear may be utilized to reduce the speed of the turbine to the required output speed for the generator.
- The internal flow passages of a steam turbine are very similar to those of the expansion section of a gas turbine. The main differences are gas density, molecular weight, isentropic expansion coefficient, and to a lesser extent, the viscosity of the two fluids.
- Compared to reciprocating steam engines of comparable size, steam turbines rotate at much higher rotational speeds, which contribute to their lower cost per unit of power developed. In addition, the inlet and exhaust valves in reciprocating steam engines cause steam pressure losses that don't contribute to power output. Such losses do not occur in steam turbines. Because of these design differences, steam turbines are more efficient than reciprocating steam engines operating from the steam at the same inlet conditions and exhausting into the same steam exhaust systems.

Material of turbine blades :

A major problem involved in turbine design is reducing the creep experienced by the blades (the tendency of a material to deform under the influence of stresses with time). Because of the high temperatures and high stresses of operation, steam turbine materials become damaged in course of time. To limit creep, thermal coatings and superalloys with grain boundary strengthening are used in blade designs. Protective coatings are used to reduce the thermal damage and to limit oxidation. These coatings are often stabilized zirconium dioxide-based ceramics. Using a thermal protective coating limits the temperature exposure of the nickel superalloy. This reduces the creep on the blades. Oxidation coatings limit efficiency losses caused by a buildup on the outside of the blades, which is especially important in the high- temperature environment. The nickel-based blades are alloyed with aluminum and titanium to improve strength and creep resistance. The microstructure of these alloys is composed of different regions of composition. Refractory elements such as rhenium and ruthenium can be

Overall efficiency of steam power plant Overall efficiency of steam turbine power plant is the product of efficiency of all components of the power plant.

It is given as: $\eta = 1 - (Q_{out}/Q_{in}) = W_{out}/Q_{in}$

Efficiency improvement

Following are the fundamental ways of improving efficiency by rising temp. at which heat is added or lowering temp. at which heat is rejected. It can be done through (super heating), (reheating) and regeneration. Following are ways of improving efficiency of the steam turbine power plant.

Specimen Calculation :

$$\eta_t = W_{out} / m_f . CV$$

$$m_f = \text{mass flow rate of fuel consumed} = \rho_f V_f / t$$

$$C V = 42700(\text{kJ/kg})$$

$$\rho_f = 820 \text{ kg/m}^3$$

Observations:

No. of obs	W_{out} (kW)	m_f kg/s)	η_t (%)

Conclusion:

Practical related questions:

1. How do you calculate the thermal efficiency of a steam turbine?
2. What determines the efficiency of a steam turbine?
3. How can you increase the efficiency of a steam turbine?
4. Why is steam turbine efficiency so low?
5. Why steam is used in turbine?

Space for answer

EXPERIMENT NO : 03

AIM OF THE EXPERIMENT :

To study the cooling tower.

APPARATUS REQUIRED : Cooling tower

Theory :

Cooling tower

A cooling tower extracts heat from water by evaporation. In an evaporative cooling tower, a small portion of the water being cooled is allowed to evaporate into a moving air stream to provide significant cooling to the rest of that water stream.

Working of Cooling towers

When water is reused in the process, it is pumped to the top of the cooling tower and will then flow down through plastic or wood shells, much like a honeycomb. The water will emit heat as it is downward flowing which mixes with the above air flow, which in turn cools the water. Part of this water will also evaporate, causing it to lose even more heat.

Types of cooling towers

1. Natural draft

Natural draft towers are typically about 120 m high, depending on the differential pressure between the cold outside air and the hot humid air on the inside of the tower as the driving force. No fans are used.

2. Mechanical Draft

Mechanical draft towers uses fans (one or more) through the tower. They are two different classes:

- (a) Forced draft cooling towers
- (b) Induced draft cooling towers

(a) Forced Draft

The forced draft tower has the fan, basin, and piping located within the tower structure. In this model, the fan is located at the base. There are no louvered exterior walls. Instead, the structural steel or wood framing is covered with paneling made of aluminum, galvanized steel, or asbestos cement boards. It is shown below:

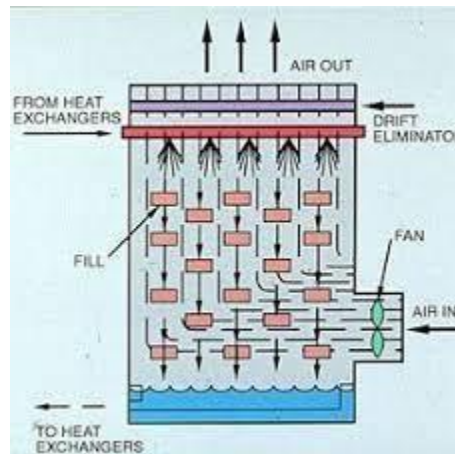

Forced draft cooling tower

(b) Induced Draft

The induced draft tower shown in the following picture has one or more fans, located at the top of the tower, that draw air upwards against the downward flow of water passing around the wooden decking or packing. Since the airflow is counter to the water flow, the coolest water at the bottom is in contact with the driest air while the warmest water at the top is in contact with the moist air, resulting in increased heat transfer efficiency.

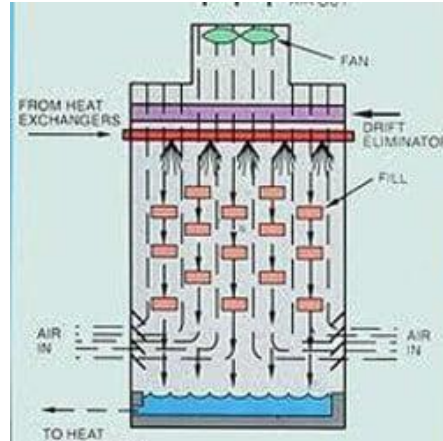

Induced draft cooling tower

Conclusion:

Practical related questions:

1. What is cooling tower explain with example?
2. What is the purpose of cooling tower?
3. What are the types of cooling towers?
4. What is cooling tower cell?
5. What is the working principle of cooling tower?
6. What is cooling tower explain with example?
7. What industries use cooling towers?
8. What is inside a cooling tower?

Space for answer

EXPERIMENT NO : 04

AIM OF THE EXPERIMENT:

Study of jet condenser.

APPARATUS USED:

Model of jet condenser.

INTRODUCTION:

A condenser is a device used in industries to convert steam into water. Condenser removes heat from the steam and gives it to the coolants, thus converting the hot steam into liquid known as condensate. A condenser works on the principle of heat transfer (heat energy always flows from higher temperature to lower temperature). It transfers heat from hot steam from the compressor to the coolants and converts it into water. **A jet condenser is a type of condenser in which steam and cooling water are mixed up in a chamber, where the steam is converted into liquid form and known as condensate. This condensate is then used for many other industrial purposes.**

Types of Jet Condenser:

There are 3 basic types of jet condensers:

1. Low-level Jet Condenser
 - Parallel Flow Jet Condenser
 - Counterflow Jet Condenser
2. Barometric Jet Condenser or High-level Jet Condenser
3. Ejector Condenser

Parallel Flow Jet Condenser:

As the name suggests in a parallel flow jet condenser the steam and water enters from the top of the condenser and hence flow parallel to each other, this is because the air pump creates a vacuum due to which there is a flow of water and steam. During the flow of water and steam, the heat from the steam gets transferred to the flowing water as we know heat always flows from higher temperature to lower temperature.

The condensate produced is collected at the bottom of the condenser. The perforated trays and air pump is used to make the process faster. There is an extraction pump located at the bottom which is used to transfer the condensate to the hot well. After passing through the hot well condensate is sent to the boiler. The design of a parallel flow jet condenser is quite simple when compared to other types of the jet condenser.

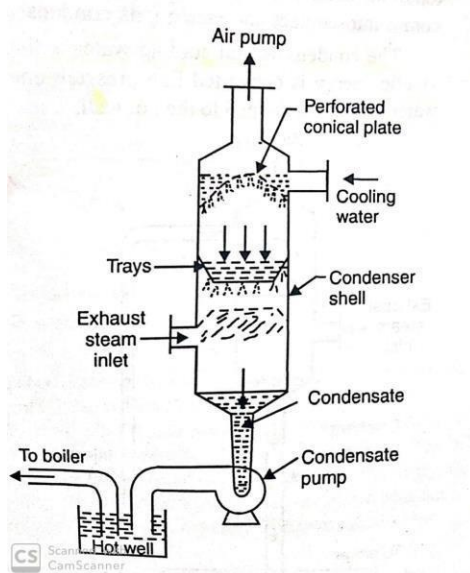

Counter Flow or Low-Level Jet Condenser:

As we can see the word “counter” itself says that the flow of steam and water are opposite to each other. In counter-flow jet condenser steam comes into the chamber from below and the cooling water comes from the top. The air pump creates a vacuum which forces cooling water into the condenser.

Water being heavy falls down and steam being light rises up through perforated trays. The falling water gets stored in the perforated trays. As soon as cooling water meets steam on its way, the process of heat transfer takes place as the result of which condensate gets accumulated in the bottom. This condensate is drawn out with the help of a pump into the hot well. The condensate is drawn out from the hot well. The equipment required for the construction of the counterflow jet condenser is less costly and simple. The quantity of cooling water required is less.

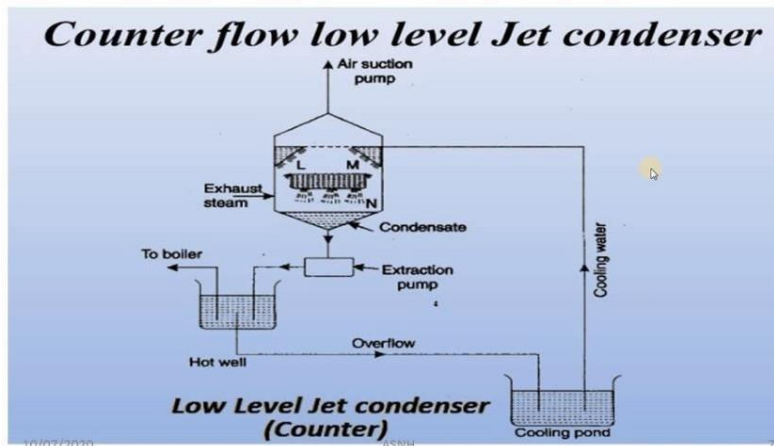

Barometric or High-Level Jet Condenser:

Barometric or high level jet condenser works much similar to counter flow jet condensers. There are a few changes in the basic structure, there is a long discharge pipe from where the condensate passes and accumulates in the hot well.

The air pump and injection pump forces cooling water from the top of the condenser and the steam is forced from below, again steam being light rises up and water being heavy falls down through perforated trays. Heat transfer between water and steam takes place producing condensate which gets settled down.

Unlike other condensers, there's no need for a pump to extract the condensate. The potential energy of condensate is high enough to make it fall this is because of the long discharge pipe.

High level jet condenser

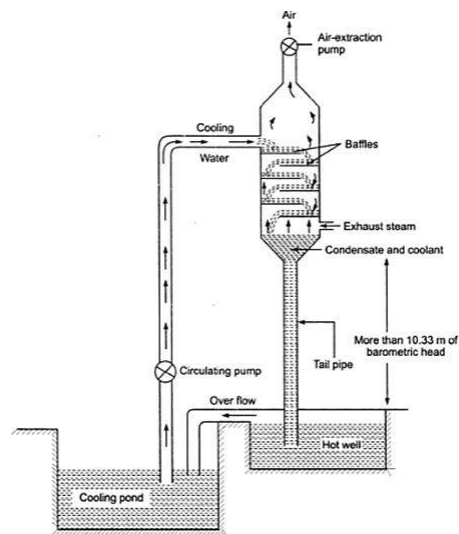

Ejector Condenser:

In the Ejector type jet condenser the steam and cooling water mixes together and pass through few metal cones. These metal cones increase the time taken by the water to come down, thus increasing the time of heat transfer.

The steam enters into the condenser through a non-return valve (the steam can only go in and can't come out of the valve).

Steam and cooling water get mixed together properly while passing through the cone where the heat transfer process takes place. There are no pumps used as the area of cross-section does not get narrow. The condensate gets collected into a hot well.

Ejector Condenser:

- Momentum of flowing water is used to remove the mixture of condensate & coolant from condenser without the use of any extraction pump.

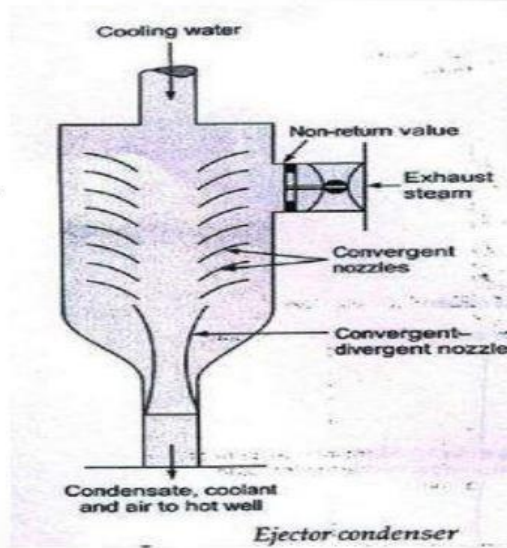

• Footer Text

Applications of Jet Condenser:

These are some of the Applications of Jet Condenser:

- A jet condenser is a direct type of condenser hence used for condensing vapors in evaporators.
- It is also used for condensing vapors in a vapor pans.
- Jet condensers are used in some of the thermal power plants to condense steam or hot air.

Advantages of Jet Condenser:

- As we can see that the construction of jet condenser is easy to understand and hence do not need many skilful labels.
- Because of the simple design installation cost of the jet condenser is low.
- Less amount of water or coolant is required in jet condensers.
- Jet condensers are quite small in size therefore they acquire less area.
- The maintenance cost of jet condensers is quite low.
- Unlike other condensers, the cooling water and steam mix together physically in jet condensers.

Disadvantages of Jet Condensers are:

- Condensate waste cannot be reused in jet condensers.
- Air pump used in jet condensers requires high power.
- Vacuum efficiency is quite low therefore there's a requirement of the pump to circulate water.
- The water pumps used also require high power to operate.
- The efficiency of jet condensers is low. This is because of the compact size of jet condensers.
- The capacity of jet condensers is also low that's why jet condensers are not used for heavy industrial purposes.
- The cooling water should be free from impurities which is not the case with jet condensers.
- In a situation, if the extraction pump fails in the case of low-level jet condensers the condenser may get flooded.

Practical related questions:-

1. Which type of jet condenser are of jet type?
2. In which jet condenser no cooling water pump is used?
3. What is the difference between jet condenser and surface condenser ?
4. What are the three functions of a condenser?
5. What is the advantages of a water-cooled condenser?
6. What is the purpose of a water-cooled condenser?

EXPERIMENT NO : 05

AIM OF THE EXPERIMENT:

Study of De-laval turbine.

APPARATUS USED:

Model of De-laval turbine.

INTRODUCTION:

The DE LAVAL STEAM TURBINE is a high speed rotary steam engine, in design and construction adapted for all purposes where the common reciprocating steam engine is now used, and for many other purposes where for various reasons no other type of engine meets impossible conditions. This is especially the case where great efficiency, great uniformity of rotation, and close regulation are important, as when used in connection with electrical machinery, centrifugal pumps, fans, blowers, etc. Its high speed and the directness of its energy conversion decreases the dimensions and weight, and simplifies the construction without impairing its efficiency, advantages which do not exist with the modern steam engine where great bulk and complexity are features indispensable to highly efficient operation.

WORKING PRINCIPLE:

Impulse turbine works on the basic principle of impulse. When the jet of water strikes at the turbine blade with full of its speed, it generates a large force which used to rotate the turbine. The force is depends on the time interval and velocity of jet strikes the blades.

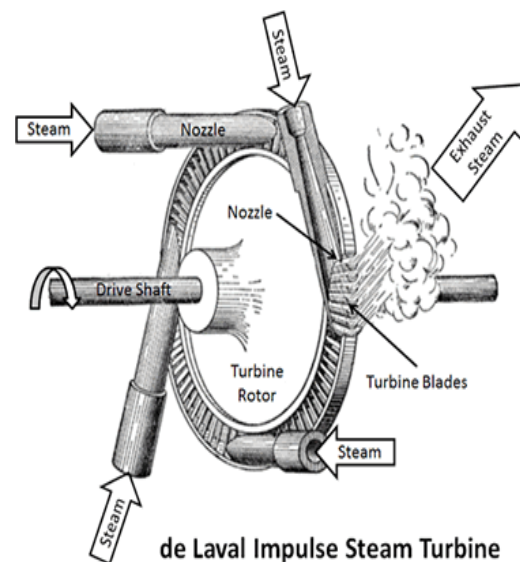
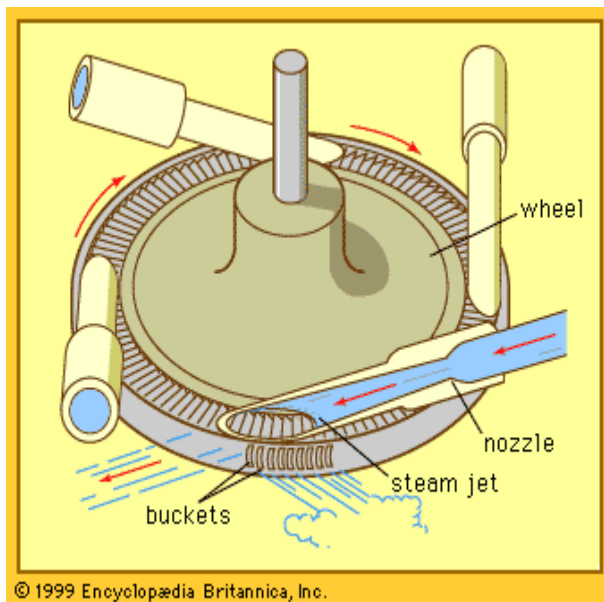

Advantage of De laval steam turbine :

- No leakage from wear,
- No bearings to adjust,
- Small friction loss,.
- High efficiency with variable loads,
- No moving parts under pressure,
- Close speed regulation,
- Simplicity of construction,

- Perfect balance—small foundations,
- Small space occupied,
- Ease of erection,
- Automatic oiling,
- No danger from water,
- And long life.

Conclusion:

In the de laval steam turbine running non-condensing, the consumption of steam per horse- power hour is less at full load than in any simple non-condensing steam engine. Condensing, the consumption is less than in an compound condensing engine. Unlike the steam engine, however, the efficiency is nearly the same throughout its entire working range. It is “the steam engine of maximum simplicity and highest thermal efficiency.”

Practical related questions:-

1. What is De Laval turbine?
2. What was the steam turbine used for?
3. What is impulse turbine?
4. What is single stage turbine?
5. Where are impulse turbine used?

Space for answer

EXPERIMENT NO : 06

AIM OF THE EXPERIMENT:

To study the spring loaded safety valve.

APPARATUS USED:

Model of spring loaded safety valve.

INTRODUCTION:

Safety valve is used to guard the boiler against the excessive high pressure of steam inside the drum. If the pressure of steam in the boiler drum exceeds the working pressure then the safety valve allows blow-off the excess quantity of steam to atmosphere. Thus the pressure of steam in the drum falls. The escape of steam makes a audio noise to warn the boiler attendant.

CONSTRUCTIONS:

1. It consists of a cast iron body having two branch pipes.
2. Two separate valves are placed over the valve seat.
3. A lever is placed over the valve by means of two pivots.
4. The lever is held tight at its proper position by means of a spring.
5. One end of spring is connected with the lever while other end with the body of the valve.
6. The valve is kept on it seats with help of spring force.

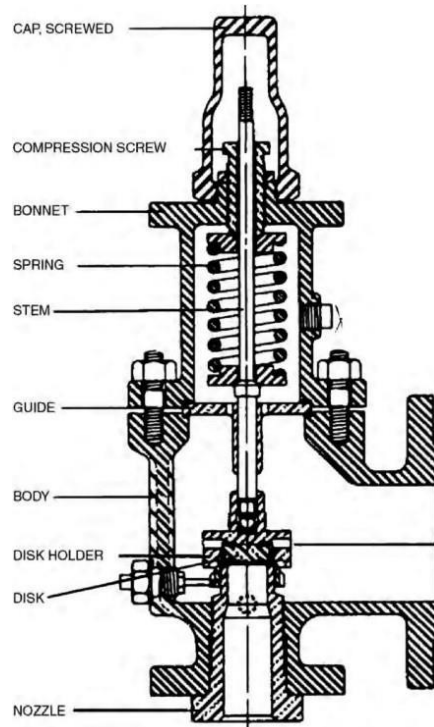

WORKING PRINCIPLE:

- In the normal condition, the downward force due to spring is higher than upward force applied by steam.
- The valve is closed due to spring force.
- When steam pressure exceeds the normal limit, upward force due to steam pressure is become higher than downward force due to spring.
- Thus the valves are lifted from their seats opening the passages for steam to release out of boiler.

Advantages of spring loaded safety valve :

1. Relieving pressure not affected by back pressure
2. Can handle higher built-up back pressure
3. Protects spring from corrosion

Disadvantages of spring loaded safety valve :

1. Bellows susceptible to fatigue/rupture
2. May release flammables/toxics to atmosphere
3. Requires separate venting system

Practical related questions:-

1. How does a spring loaded safety valve work?
2. How many types of safety valves are there?
3. What is the use of spring loaded safety valve in a boiler?
4. What is the difference between safety valve and relief valve?
5. Why is a safety valve provided in a boiler feed pump?

Space for answer

EXPERIMENT NO : 07

To study the following steam generators (boilers) models

AIM OF THE EXPERIMENT:

To study and sketch about Lancashire Boilers

APPARATUS USED:

Model of Lancashire Boilers

INTRODUCTION:

A Lancashire Boiler is fire tube boiler. Its normal working pressure range is 15 bar and steaming capacity is about 8000 Kg/h. Its size varies from about 8 meters to 9 meters in length and from 2 to 3.5 meters in diameter.

CONSTRUCTION DETAILS:

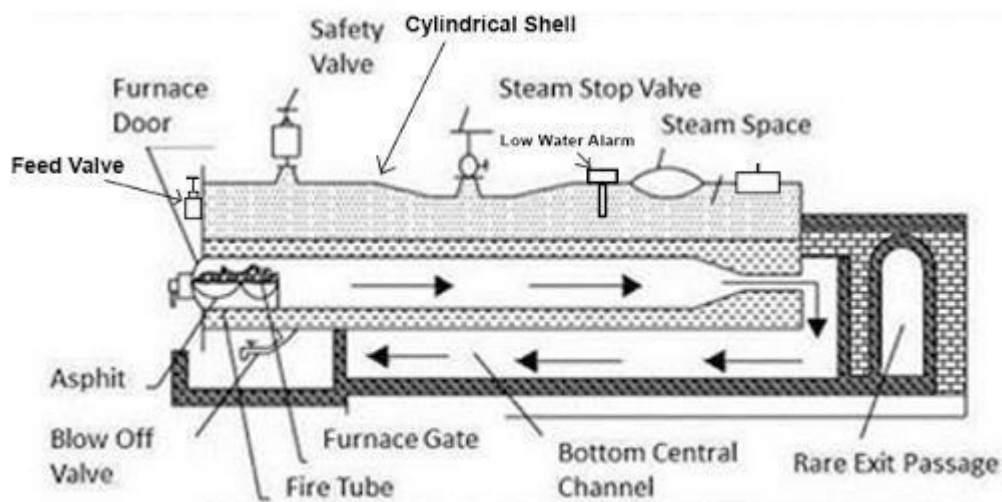

Lancashire Boiler

It consists the following parts:

1. **Feed Check Valve:** Feed water is supplied to the boiler under pressure, feed check valve stops it escaping back.
2. **Pressure Gauge:** It is used for measuring the pressure of steam.
3. **Water level Gauge:** It indicates the level of water in the boiler.
4. **Dead weight safety valve:** It is for safety against pressure in excess of the rated pressure.
5. **Steam stop valve:** It opens and closes the supply of steam for using.
6. **Man Hole:** It is for cleaning and inspecting the drum.
7. **Fire Grate:** The grate in which the solid fuel is burnt.
8. **Fire Bridge:** This is used for deflecting the gases of combustion upwards.
9. **Flue Tubes:** These are for the first pass of the flow of the flue gases. The flue tubes are tapered being larger in diameter at the front and smaller at the back.
10. **Boiler Shell:** It is used for containing water and steam. It is made of several welded and riveted rings of Simens-martin open hearth steel plates.

11. **Dampers:** It is used for controlling the flow of flue gases. These are iron doors which slide up and down in the grooves by rope and pulley.

12. **Blow off cock:** Blow off cock is provided at the bottom of the shell by a bent pipe to blow off sludge at intervals. Since the water shell is not perfectly horizontal, a few degrees tilting towards the front enables all the sediments to accumulate in front near the blow off cock.

Working Principle of Lancashire Boiler:

This Lancashire boiler works on the basic principle of the heat exchanger. It is basically a shell and tube type heat exchanger in which the flue gases flow through the tubes and the water flows through a shell. The heat is transfer from flue gases to the water through convection. It is anatural circulation boiler that uses the natural current to flow the water inside the boiler.

Applications of Lancashire Boiler:

- The Lancashire boiler is used to drive steam turbines, locomotives, marines, etc.
- It is used in industries like paper industries, textile industries, sugar industries, tire industries, etc.

Advantages of Lancashire Boiler:

- This has high thermal efficiency. Thermal efficiency is about 80 to 90%.
- This is easy to operate.
- It can easily meet the load requirement.
- Easy to maintain.
- Low consumption of electricity due to natural circulation.

Disadvantages of Lancashire boiler:

- This is a low-pressure type boiler, so high-pressure steam is not produced.
- It has a limited grate area due to the small diameter of the flue tubes.
- The steam production rate is low. It is about 9000 kg/hr.
- Corrosion occurs in the water legs.
- This boiler requires more floor space.

Practical related questions:-

1. What type of boiler is Lancashire?
2. What is the maximum working pressure of a Lancashire boiler?
3. What is the function of boiler?
4. What are the main parts of Lancashire boiler?

AIM OF THE EXPERIMENT

To study and sketch about the model of Cornish Boiler

APPARATUS USED:

Model of Cornish Boiler

INTRODUCTION:

Cornish boiler is a fire tube boiler that works is to produce steam by the burning of fuel(coal) and further used in the steam turbine, textile or sugar mill industry, and so on.

CONSTRUCTION OR PARTS OF CORNISH BOILER:

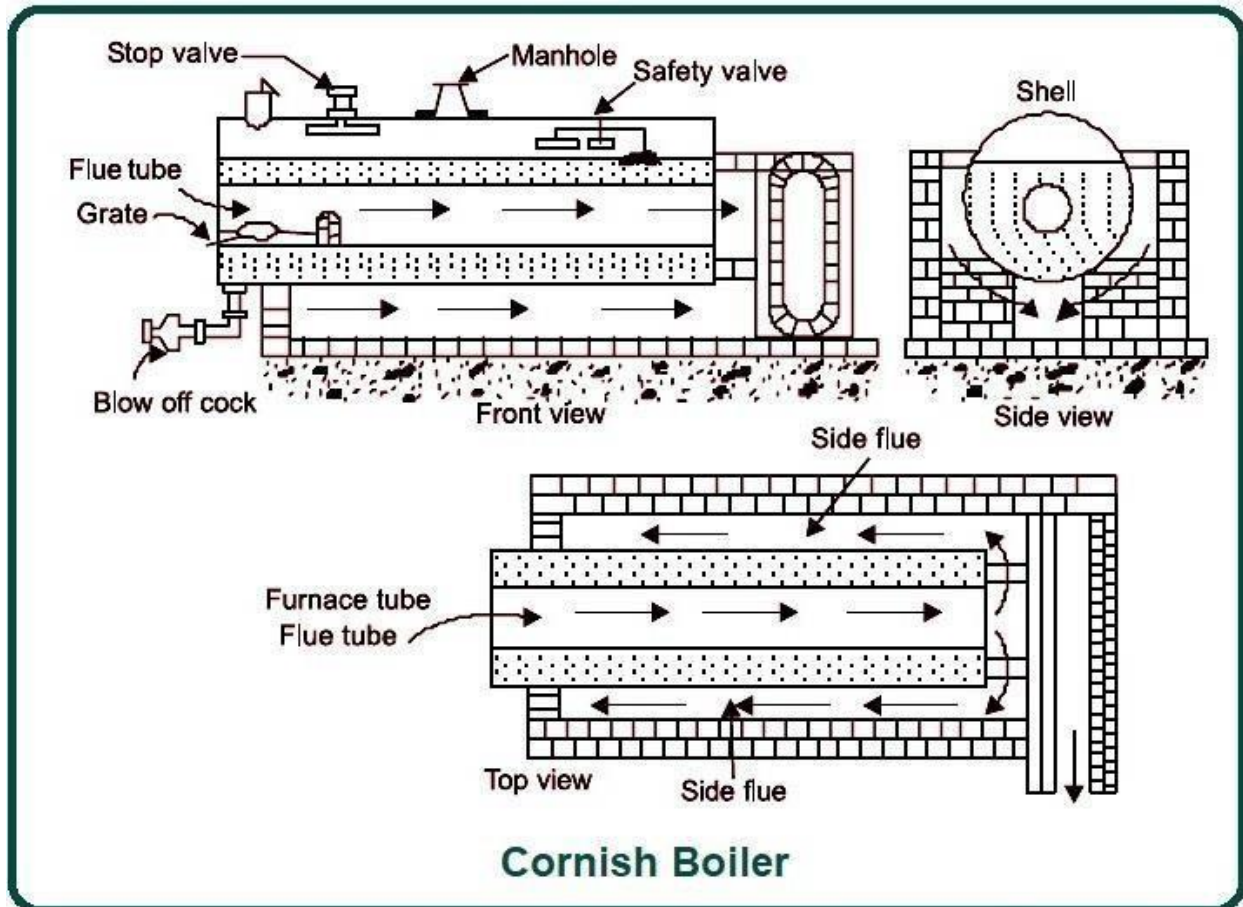

A Cornish Boiler consists of several parts those are:

- Shell
- Grate
- Furnace
- Combustion chamber
- Chimney
- Smokebox

- Water level indicator
- Safety Valve
- Man Hole
- Stop Valve
- Blow off valve

Shell:

A shell contains water inside it as well as a tube. The transfer of heat between water takes place in the shell and also the shell is like it covers all the components of the boiler and it is also called the main body.

Grate:

It is a door form which the fuel is provided for burning and generating heat. The grate is located at the bottom of the furnace.

Furnace:

A furnace works like a mediator you know why? because it is connected between the fire tube and the combustion chamber. Here fuel burns and produces Heat.

Combustion chamber:

Here in the combustion chamber the fuel burns and produces heat which is then supplied to the tube here water is surrounded. The combustion chamber is connected to the furnace.

Ash pit:

Here ash of fuel which is completely burned and no use inside the boiler.

Chimney:

The chimney is here for releasing the exhaust gases to the atmosphere.

Smokebox:

The smokebox is provided here to collect the smoke and further sends it to the chimney.

Water level indicator:

This is an instrument which gives the detail of the water level of the boiler. This also works when water exceeds the limit or water down the limit.

Safety Valve:

The safety valve is another type instrument which is used for safety purpose and This also works when no other indicators work.

Man Hole:

It is the main hole from which when any components inside the boiler get damage then an engineer will enter and replace it from here.

Stop Valve:

The stop valve is also used for regulating the control of things.

Blow off valve:

A blow off valve is used to clean the boiler by discharging the water and sediments from the bottom of the boiler

WORKING PRINCIPLE OF CORNISH BOILER:

The working substance here is coal. At the grate, the fuel which is coal is provided and it sends to the furnace. Here we burn the fuel by providing some amount of fire to it. So as we know this is a single large tube boiler. Burning of coal produces the heat which is then sent to the tube and here water is surrounded. we supply water here and with the use of an instrument, water level indicator we measure the level of water. So now tube has as much heat that water gets start heated which means water first converts into saturated steam and then it further heated and converts into superheated steam which is now working steam. The steam can be further used for different purposes. Meanwhile here the burning coal ash comes to the ash pit and from here it comes to the smokebox and the gas will release to the chimney to the environment and we extract the ash from the system and clean this.

Advantages of Cornish Boiler:

- The designs are simple and easy.
- The construction is easy and its compactness.
- It is a portable types boiler.
- The maintenance cost is low.
- It can handle load fluctuation to some extent.

Disadvantages of Cornish Boiler:

- It is a type of low production steam rate which is around 1350 kg/hour.
- The pressure is low comparatively other boilers which are 12-13 bar.

Applications of Cornish Boiler:

- It is used in several industries like sugar, mill, chemical, and other more industry.
- It is also used to run the steam turbine.
- Cornish Boiler used in marines.

Practical related questions:-

1. What is Cornish boiler?
2. What causes failure of boiler tube?
3. What Cornish means?
4. What is water tube boiler?
5. What is water wall in boiler?

AIM OF THE EXPERIMENT

To study and sketch about the model of Babcock Wilcox Boiler

APPARATUS USED:

Model of Babcock Wilcox Boiler

INTRODUCTION:

Babcock Wilcox Boiler is a water tube boiler. Evaporative capacity of such boilers ranges from 20,000 to 40,000 kg/hr of steam and operating pressure is about 40 bar.

CONSTRUCTION:

It consists of high pressure drum mounted at the top. From each end of the drum connections are made with the upper header and down tube header. A large number of water tubes connects the uptake and down take header. The water tubes are inclined 25 to 35 degree to promote water circulation. The heating surface of the unit is the outer surface of the tubes and half of the cylindrical surface of water drum which is exposed to flue gases. A mud box is attached to the bottom of the down take header.

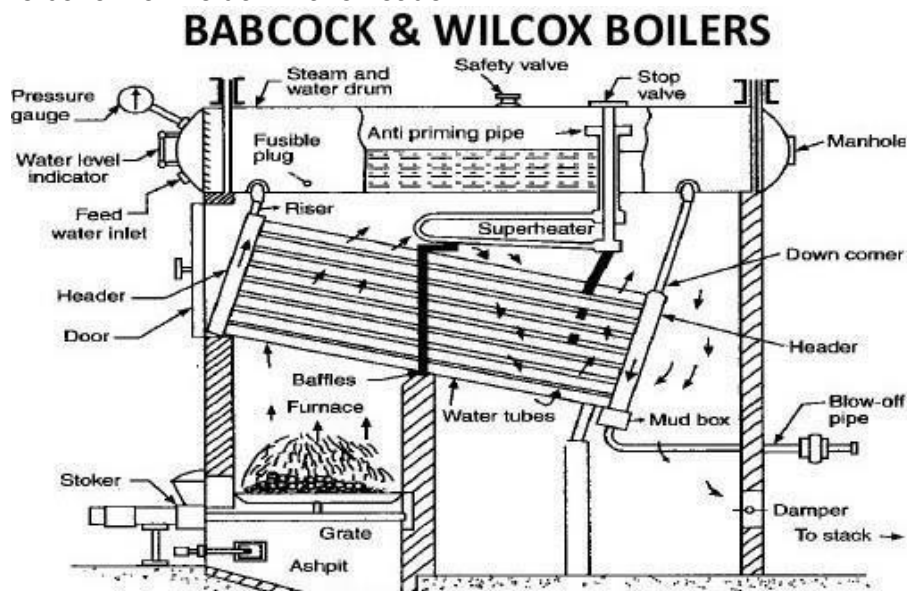

The whole of the assembly of water tubes is hung along with the drum from steel girder frame by steel rods called slings in a room made of masonry work, lined with fire bricks. Below the uptake header the furnace of boiler is arranged. The coal is fed to chain grate stoker. There is a bridge wall deflector which deflects the combustion gases upwards. Two baffles are also arranged which provide three passes of the flue gases. A damper is placed at the inlet of the chimney to regulate the draught. Different other mountings and accessories are given below:

Pressure Gauge, Water gauge, safety valve, feed water inlet, Headers, Non return valve, Anti priming pipe, Super heater, Baffles, Fire Grate, Ash Pot, Clean out doors, Riser, Blow off pipe, Damper etc.

A Babcock and Willcox Boiler Parts or Construction consists of:

- Drum
- Water Tubes
- Uptake and Downtake header
- Grate

- furnace
- Baffles
- Superheater
- Mud box
- Inspection Door
- Water Level Indicator
- Pressure Gauge

Drum:

This is a horizontal axis drum which contains water and steam.

Water tubes:

Water tubes are placed between the drum and furnace in an inclined position (at an angle of 10 to 15 degrees) to promote water circulation.

Uptake and Downtake Header:

This is present at the front end of the boiler and connected to the front end of the drum. It transports the steam from the water tubes to the drum. and

This is present at the rear end of the boiler and connects the water tubes to the rear end of the drum.

It receives water from the drum.

Grate:

Coal is fed to the grate through the fire door.

Furnace:

The furnace is kept below the uptake-header.

Baffles:

The fire-brick baffles, two in number, are provided to deflect the hot flue gases.

Superheater:

It increases the temperature of saturated steam to the required temperature before discharging it from the steam stop valve.

Mud Box:

This is used to collect the mud present in the water.

Mud box is provided at the bottom end of the down-take header.

Inspection Door:

Inspection doors are provided for cleaning and inspection of the boiler.

Water Level Indicator:

The water level indicator shows the level of water within the drum.

Pressure Gauge:

The pressure gauge is used to check the pressure of steam within the boiler drum.

WORKING PROCESS:

The hot combustion gases caused by burning of fuel on the grate rise upwards and are deflected by the bridge wall deflection and pass over to the front portion of the water tubes and drum. In this way they complete the pass, with provision of baffles they deflect downwards and complete second pass. Again with the provisions of baffles they rise upwards and complete the third pass and finally come out through the chimney. During their travel they give heat to water and steam is formed. The circulation of water in boiler is natural circulation set up by convective currents.

Feed water supplied by a feed water inlet pipe. The hottest water and steam rises from the tubes to the uptake header and then through the riser enters the boiler drum. The steam vapours escape through the water to upper half of the drum. The cold water flows from the drum to the down take header and thus the cycle is completed. The flue gases passing over the flue tubes produce superheated steam. The steam thus superheated is finally supplied to be used through a steam stop valve. The super heaters remains flooded until the steam reaches the working pressure. The superheater is then drained and steam is allowed to enter in it for superheating purposes.

USES:The Babcock Wilcox Boiler is used in electric power plants for running steam turbines.

Advantages of Babcock and Wilcox:

- The overall efficiency of this boiler is high.
- The steam generation rate is higher about 20 ton per hour at pressure 10 to 20 bars.
- The tubes can be replaced easily.
- The boiler can expand and contract freely.
- It is easy to repair maintenance and cleaning.

Disadvantages of Babcock and Wilcox Boiler:

- It is less suitable for impure and sedimentary water, as a small deposit of scale may cause the overheating and bursting of tubes. Hence, water treatment is very essential for water tube boilers.
- Failure in feed water supply even for a short period is liable to make the boiler overheated. Hence the water level must be watched very carefully during the operation of a water tube boiler.

Practical related questions:-

1. Why water tubes are inclined in Babcock Wilcox boiler?
2. How many fire tubes Babcock & Wilcox boiler have?
3. What is the function of baffle plate in Babcock Wilcox boiler?
4. In which boiler super heater is used?
5. What is a Babcock and Wilcox boiler on what principle it works?

Space for answer

AIM OF THE EXPERIMENT

To study and sketch about the model of Vertical water tube boiler.

APPARATUS USED:

Model of Vertical water tube boiler.

INTRODUCTION:

Generally, a vertical **fire tube boiler** is a vertical type boiler. In this boiler heating surface is composed of multiple small fire tubes and is arranged vertically. In this post, we will learn the Construction and Working Principle of Vertical Boiler.

CONSTRUCTION:

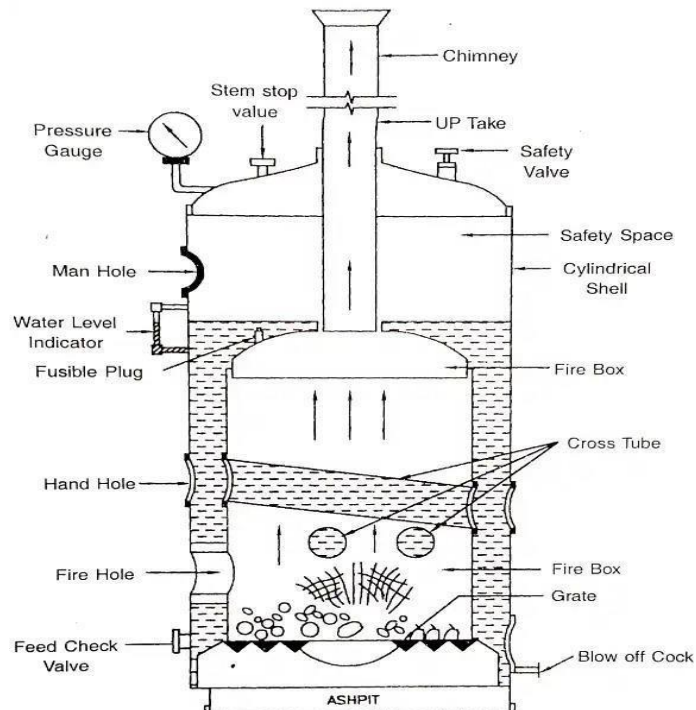

The interior parts of this boiler have been separated by four-way and those are,

1. Furnace and Combustion Chamber.
2. Water Chamber.
3. Steam Chamber.
4. Chimney.

Furnace and Combustion Chamber:

The furnace is an important part of any kind of **boiler**. It also called the heating surface for a boiler. Fuel used to burn inside the boiler furnace and heat is generated. Then heat transfer to the water inside the boiler and became steam. A brick bridge is used inside the combustion

chamber. By using this brick bridge less fuel is needed and the efficiency of the boiler is increased.

A corrugated shape will be found with the furnace plate. This corrugated plate is made with some metal alloy and its strength is very high. One of the main reasons is that it is the main heating section for this **boiler**. This plate thickness can be 1.54cm. It is one of the thin plates inside the boiler. For this reason, this plate can be heated so first and heat transfer to the water is relatively high.

Water Chamber:

This chamber contains water. After the water treatment procedure, feed water stored in the water chamber. This feed water flows through the inside or outside of the tube and gets heated by the furnace generated flue gases. After, this feed water becomes steam.

Steam Chamber:

Generated steam inside the boiler is stored in this steam chamber when it is in the primary stage. From this steam chamber, steam transfer to the super heater. Then superheated steam transfer to the prime mover. You can say saturated steam is stored in this steam chamber.

Chimney:

When you are burning fuel inside the furnace then smoke and gases will generate. By using the chimney this smoker and hot gases release to the atmosphere. Boiler chimney helps to releases all fly ash, burn flue gases and smokes to the open air. **Boiler** chimney needs to be the long height that by using this all smoke and gases can release at maximum height. For this height smoke and gases has less amount of negative in the environment.

To get better efficiency of a boiler, the draft is needed at the furnace. Natural draft is created by the chimney and it helps to burn fuel in the furnace. If the height of the chimney is high then natural draft power will high. But making a long height chimney is much expensive. For this reason, long height chimney is not available at present time. In modern boiler induced draft fan (I.D Fan) is used to release smoke by a small chimney.

Working of Vertical Boiler:

When fuel is placed in the furnace and burns then hot flue gas is generated. Then these hot flue

is converted in saturated steam. You can call this saturated steam as primary steam. This saturated steam is stored at the steam chamber. From the steam, the chamber is transferred to the boiler superheater. This superheating process makes saturated steam to working steam.

After that superheated steam is transfer to the prime mover. All hot burn flue gases, smoke, and ash are release out from the boiler by a chimney. Boiler chimney creates a natural draft to increase boiler efficiency.

Advantages

The main advantages of a vertical boiler are:

- Small footprint - where width and length constraints are critical, use of a vertical boiler permits design of a smaller machine.
- Water-level tolerance – The water level in a horizontal boiler must be maintained above the crown (top) of the firebox at all times, or the crown plate could overheat and buckle, causing a boiler explosion.
- Simpler (major) maintenance - A vertical boiler is usually mounted on a frame on the vehicle, allowing easy replacement.

Disadvantages

The main disadvantages of a vertical boiler are:

- Size – The benefits of a small footprint are compromised by the much greater height required.^[1] The presence of over-bridges limits the height of steam vehicles, and this in turn restricts the size (and hence steam production) of the boiler.^[2]
- Grate area - This is limited to the footprint of the boiler, thus restricting the amount of steam that may be produced.^[2]
- Short tubes – Boiler tubes must be kept short to minimise height. As a result, much of the available heat is lost through the chimney, as it has too little time to heat the tubes.^[2]
- Sediment - Sediment may settle on the bottom tube sheet (the plate above the firebox) insulating the water from the heat and allowing the sheet to burn out.

Applications –

1. Railway locomotives
2. Steam lorries
3. Steam tractors
4. Steam rollers
5. Steam donkeys
6. Steam shovels and cranes
7. Marine applications
8. Stationary applications

Practical related questions:-

1. How does water tube boiler work?
2. What is the difference between fire tube and water tube boiler?
3. What is the purpose of fire door in boiler?
4. Where are water tube boilers used?
5. Where are water tube boilers used?
6. Why water tube boiler is more efficient?

EXPERIMENT NO:8

AIM: study of environmental impact of power plant.

THEORY:-

GLOBAL ENVIRONMENTAL IMPACTS

CLIMATE CHANGE:

The greenhouse effect means the absorption of some of the heat radiated from the Earth's surface by so-called greenhouse gases (water vapour, CO₂ and other compounds in the lower atmosphere). If the levels of, e.g., CO₂ in the atmosphere progressively increase as a result of human activity, it is thought that this will eventually increase the natural greenhouse effect and result in a rise of temperature in the lower atmosphere leading to wide-spread climate change.

OZONE LAYER DEPLETION:

Ozone layer depletion is the destruction of the stratospheric ozone layer that shields the earth from ultraviolet radiation that is harmful to life. This destruction of ozone is mainly caused by the breakdown of certain chlorinated, brominated or other halogenated hydrocarbons. These compounds break down when they reach the stratosphere and then catalytically destroy ozone molecules.

LOCAL AND REGIONAL ENVIRONMENTAL IMPACT

ACIDIFICATION :

The environment can either be acidified by direct emissions of acids to aquatic or terrestrial systems or through a complex chemical reactions. Such reactions occur when emissions of sulphur and nitrogen compounds and other substances are transformed in the atmosphere, often far from the original sources, and then deposited on earth in either wet or dry form. The wet forms, popularly called 'acid rain', can fall as rain, snow, or fog. The dry forms are acidic gases or particles. Acidification is linked to adverse effects on aquatic ecosystems and terrestrial plant life, especially in areas with poor neutralising (buffering) capacity. Acids can also leach out poisonous trace metals from the rock matrix in the soil, thus causing damage to flora, fauna and humans. The effects are very site-specific. Here an approach, in which the effect is defined as the amount of protons (H⁺) released in a terrestrial system in SO₂-equivalents, is used.

EUTROPHICATION :

There are two main issues of eutrophication. The first is the adverse effect from a decline in dissolved oxygen levels in the aquatic environment. This can happen either when the introduction of a limiting nutrient (generally P or N)

species) and thus to more biomass, or when more biomass is introduced directly. The decay of this biomass may lead to a decrease in oxygen levels. The second issue of eutrophication is the fertilisation of terrestrial plants, due to the introduction of nitrogen species (NOX, NH₃ or NH₄) (International Organisation for Standardisation, 1998).

PHOTOCHEMICAL OXIDANT FORMATION :

Photochemical smog affects human health, as well as plants and animals. Its production is the result of a highly complex combustion or mineralisation reaction of organic materials in the atmosphere (volatile organic compounds, VOCs). The reaction occurs when the organic molecules are combined with NOX. The active component is ozone, a by-product of the above reaction (International Organisation for Standardisation, 1998).

ECOTOXIC IMPACT :

In this sub-category all (e.g., carcinogenic, pathogenic) substances that can have a toxic effect on the environment, i.e. flora, fauna or humans, are aggregated.

Ecotoxicity is aggregated in three classes:

1. toxically contaminated soil
2. toxically contaminated water
3. radioactivity

Practical related questions:-

- 1) How does power plant affect the environment?
- 2) Which Power Plant causes least environmental pollution?
3. What environmental issues are linked to the use of diesel fuels?
- 4) Which of the following power plant causes highest amount of air pollution?
5. Which of the following pollutants emitted by thermal power plant causes irritation in Eyes?
6. Which of the following pollutants emitted by thermal power plant is a cause of global warming?
7. Which of the following pollutant causes acid rain?
8. Which of the following is mostly affected by thermal power plant pollutants?